

# TK

## Inline Circulation Pump Product Catalogue.



**TESK**

South Africa.

**Important information:**

This document should be read in conjunction with the technical manual from the suppliers. The contents in this document remains the property of Vansan SA (Pty) Ltd and may not be distributed without the explicit written consent of Management.



# Contents

Introduction & Overview	2
TK32-2	4
TK40-2	10
TK50-2	12
TK65-2	16
TK80-2	20
TK100-2	22
TK125-4	24
TK150-4	26
TK200-4	28
TK250-4	32
TK300-4	36



**South Africa.**



# Overview

## Introduction

The TK Series is a single-stage vertical centrifugal pump which completes liquid transportation by the centrifugal force generated by the impeller of the rotary pump. The pump body and motor consist of the main shaft, impeller, casing and mechanical seal, which is all connected by a coupling.

These pumps can withstand high temperatures and pressures. They are mainly used for HVAC systems as well as in booster systems for water supply.

The piping structure ensures that the pump is directly installed in the same horizontal system with the same in- and outlet diameters. This design makes the structure and piping of the pump more compact.

## Pump Structure Design

Pull-up design with separate motor and pump body. The pump cover bracket acts as a connection between the motor and pump body, using the O-ring as a seal. The flange sizes meet the requirements of PN16 in GB/T17241.6 or ISO7005-2/DIN2501

## Liquid Temperature

Normal temperature pump:  $-15^{\circ}\text{C}$  to  $+70^{\circ}\text{C}$   
Hot temperature pump:  $-15^{\circ}\text{C}$  to  $+105^{\circ}\text{C}$

## Ambient temperature

If the ambient temperature exceeds  $+40^{\circ}\text{C}$  or the pump is installed at an altitude exceeding 1000m above sea level, the motor output power (P2) will decrease. In such cases it is necessary to use a motor with a higher rated output.

## Motor

Totally enclosed, fan-cooled, 2-pole standard motors.  
Enclosure class: IP55  
Insulation class: F  
Voltage: 3-phase 220-240V  
3-phase 380-400V  
Single phase 220-240V (0.37kW-2.2kW)

## Pump operating conditions

Pumping liquids which are thin, clean, non-flammable, non-combustible or non-explosive with no solid particles or fibres.  
Maximum ambient temperature:  $+40^{\circ}\text{C}$   
Maximum altitude above seal level: 1000m

## Performance curves

Motor speeds are based on 2900rpm or 2950rpm  
Tolerances to ISO9906  
Measurements have been made with airless water at  $20^{\circ}\text{C}$   
The curves apply to the following kinematic viscosity:  $1\text{mm}^2/\text{s}$ .  
It is advisable to determine the pump selection operating within the bold curve of the pump performance.

## Maximum working pressure

Normal pressure type: PN12bar  
High pressure type: PN16bar

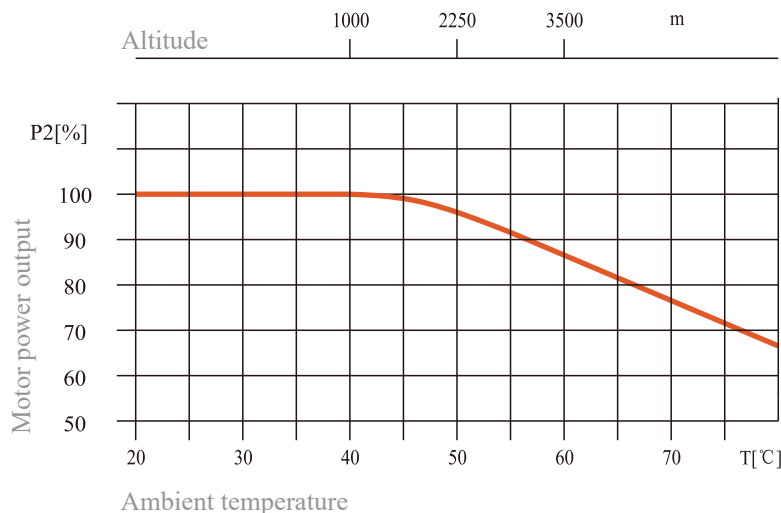

## Pump performance range

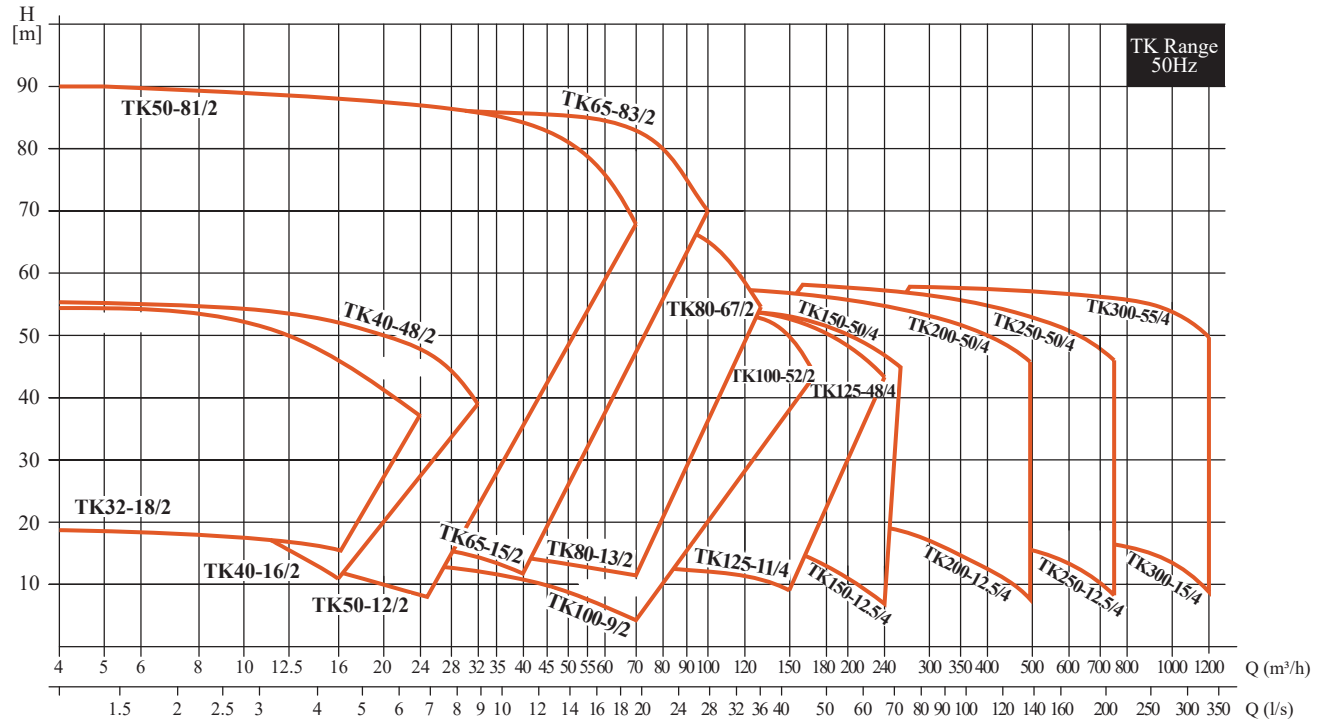

## Minimum inlet pressure, NPSH

Cavitation may occur if the following conditions exist during the operation of the water pump:

- The water tank or pool is lower than the pump inlet
- Actual flow is significantly greater than the rated flow

To avoid cavitation, make sure there is a minimum pressure on the inlet side of the pump. The maximum suction range H (m) can be calculated as follows:

- $P_b$  = Atmospheric pressure (atmospheric pressure can be set to 1bar)
- $H_T$  = Net positive suction head (can be read from the maximum possible flow rate on the NPSH curve).
- $H_l$  = Pipeline loss at inlet
- $H_v$  = Vaporization pressure
- $H_S$  = Safety margin, minimum 0.5m head

If the calculated value of H is positive, the pump can be operated at the maximum suction range H.

If the calculated value of H is negative, there must be a head with a minimum inlet pressure H.

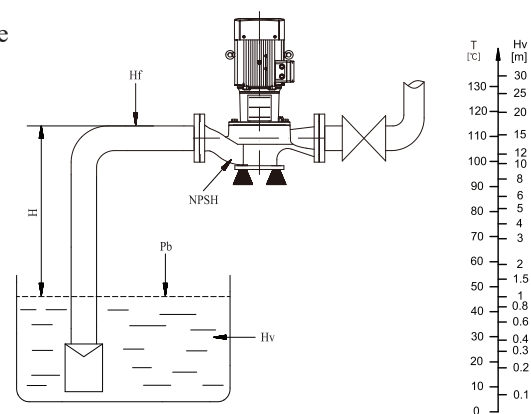

## Overview

### Pump labelling

**TK 65-34/2**

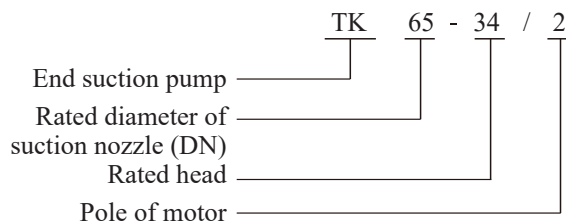

### Applications

#### Water supply

- Water filtering
- Boosting
- Pressurization for hotels
- Industrial pressurization

#### Industrial boosting

- Cleaning systems
- High pressure flushing systems
- Firefighting systems
- Vehicle cleaning equipment

#### Industrial liquid transport

- Air-conditioning systems
- Boiler feed water
- Condensing systems & cooling towers
- Machine tool cooling lubrication systems

#### Water treatment

- Ultra-filtration systems
- Reverse osmosis systems
- Distillation systems
- Separator
- Swimming pools

#### Irrigation

- Regional irrigation
- Sprinkler irrigation
- Drip irrigation
- Greenhouse irrigation



## Pump parameters

Model	Q (m <sup>3</sup> /h)	H (m)	n (r/min)	Voltage (V)	
				1 x 220V	3 x 380V
				kW	
TK32-18/2	8	18	2900	1.1	1.1
TK32-21/2	12.5	21		1.5	1.5
TK32-25/2	12.5	25		2.2	2.2
TK32-32/2	12.5	32			3
TK32-38/2	12.5	38			4
TK32-50/2	12.5	50			5.5
TK40-16/2	12.5	16		1.1	1.1
TK40-20/2	12.5	20		1.5	1.5
TK40-18/2	20	18		2.2	2.2
TK40-25/2	20	25			3
TK40-30/2	25	30			4
TK40-36/2	25	36			5.5
TK40-48/2	25	48			7.5
TK50-32/2	12.5	32			3
TK50-38/2	12.5	38			4
TK50-48/2	12.5	48			5.5
TK50-12/2	16	12		1.1	1.1
TK50-15/2	20	15		1.5	1.5
TK50-18/2	25	18		2.2	2.2
TK50-24/2	25	24			3
TK50-28/2	30	28			4
TK50-35/2	30	35			5.5
TK50-40/2	35	40			7.5
TK50-50/2	40	50			11
TK50-60/2	50	60			15
TK50-70/2	50	70			18.5
TK50-81/2	50	81			22
TK65-36/2	25	36			5.5
TK65-48/2	25	48			7.5
TK65-15/2	30	15		2.2	2.2
TK65-19/2	30	19			3
TK65-22/2	40	22			4
TK65-30/2	40	30			5.5
TK65-34/2	50	34			7.5
TK65-40/2	50	40			11
TK65-50/2	50	50			15
TK65-61/2	50	61			18.5
TK65-67/2	50	67			22
TK65-83/2	50	83			30
TK80-13/2	50	13			3
TK80-18/2	50	18		4	

# Overview

## Pump parameters

Model	Q (m <sup>3</sup> /h)	H (m)	n (r/min)	Voltage (V)		
				1 x 220V	3 x 380V	
				kW		
TK80-22/2	50	22	2900		5.5	
TK80-28/2	50	28			7.5	
TK80-40/2	50	40			11	
TK80-48/2	50	48			15	
TK80-30/2	80	30			11	
TK80-38/2	80	38			15	
TK80-47/2	80	47			18.5	
TK80-54/2	80	54			22	
TK80-67/2	80	67			30	
TK100-9/2	50	9			2.2	2.2
TK100-15/2	60	15				4
TK100-17/2	80	17				5.5
TK100-22/2	80	22				7.5
TK100-27/2	100	27				11
TK100-33/2	100	33				15
TK100-40/2	100	40				18.5
TK100-48/2	100	48				22
TK100-52/2	130	52			30	
TK125-11/4	120	11	1450		5.5	
TK125-14/4	120	14			7.5	
TK125-18/4	160	18			11	
TK125-22/4	160	22			15	
TK125-28/4	160	28			18.5	
TK125-32/4	160	32			22	
TK125-40/4	160	40			30	
TK125-48/4	160	48			37	
TK150-12.5/4	200	12.5			11	
TK150-17/4	200	17			15	
TK150-21/4	200	21			18.5	
TK150-25/4	200	25			22	
TK150-33/4	200	33			30	
TK150-40/4	200	40			37	
TK150-50/4	200	50			45	
TK200-15/4	300	15			18.5	
TK200-18/4	300	18			22	
TK200-24/4	300	24			30	
TK200-30/4	300	30			37	
TK200-35/4	300	35		45		
TK200-44/4	300	44		55		
TK200-53/4	300	53		75		
TK200-12.5/4	400	12.5		22		



## Pump parameters

Model	Q (m <sup>3</sup> /h)	H (m)	n (r/min)	Voltage (V)	
				1 x 220V	3 x 380V
				kW	
TK200-20/4	400	20	1480		30
TK200-23/4	400	23			37
TK200-27/4	400	27			45
TK200-32/4	400	32			55
TK200-43/4	400	43			75
TK200-50/4	400	50			90
TK250-15/4	500	15			30
TK250-18/4	500	18			37
TK250-21/4	500	21			45
TK250-27/4	500	27			55
TK250-36/4	500	36			75
TK250-44/4	500	44			90
TK250-53/4	500	53			110
TK250-12.5/4	630	12.5			30
TK250-14/4	630	14			37
TK250-17/4	630	17			45
TK250-20/4	630	20			55
TK250-26/4	630	26			75
TK250-32/4	630	32			90
TK250-40/4	630	40			110
TK250-50/4	630	50			132
TK300-15/4	900	15			55
TK300-20/4	900	20			75
TK300-25/4	900	25			90
TK300-30/4	900	30			110
TK300-35/4	900	35			132
TK300-44/4	900	44			160
TK300-55/4	900	55			200

# TK32

## Performance data

Model	Power		Q (m <sup>3</sup> /h)	2	4	6	8	10	12.5	14	16
	kW	HP									
TK32-18/2	1.1	1.5	<b>H (m)</b>	19.3	19.1	18.7	18.0	16.7	14.3		
TK32-21/2	1.5	2.0		24.4	24.2	23.9	23.3	22.5	21.0	19.4	15.8
TK32-25/2	2.2	3		28.2	28.2	28.0	27.5	26.7	25.0	23.6	20.6
TK32-32/2	3	4		34.2	34.2	33.9	33.6	33.1	32.0	30.8	28.1
TK32-38/2	4	5.5		39.7	39.8	39.7	39.4	39.0	38.0	37.0	35.1
TK32-50/2	5.5	7.5		51.6	51.6	51.4	51.1	50.7	50.0	49.3	47.9

## Installation dimensions & weight

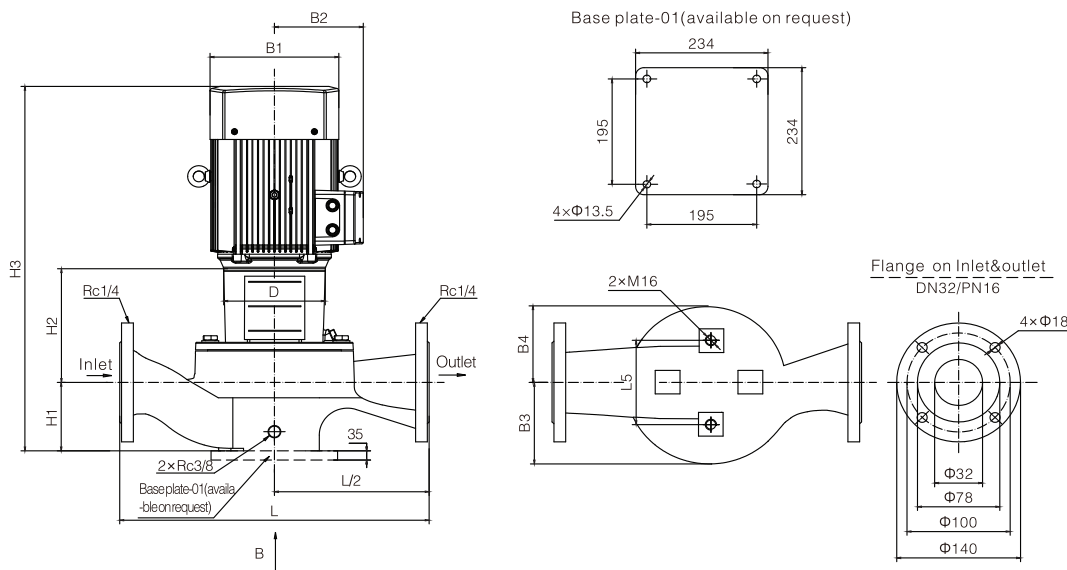

Model	Dimensions (mm)											Weight (kg)
	D	B1	B2	B3	B4	B5	H1	H2	H3	L1	L2	
TK32-18/2	120	170	142	124	116	144	100	189	540	340	170	36
TK32-21/2	140	190	155	124	116	144	100	199	592	340	170	40
TK32-25/2	140	190	155	124	116	144	100	199	592	340	170	42
TK32-32/2	160	197	165	124	116	144	100	205	619	340	170	48
TK32-38/2	160	230	188	142	142	144	100	207	642	440	220	64
TK32-50/2	200	260	208	142	142	144	100	227	737	440	220	85

## Performance curves

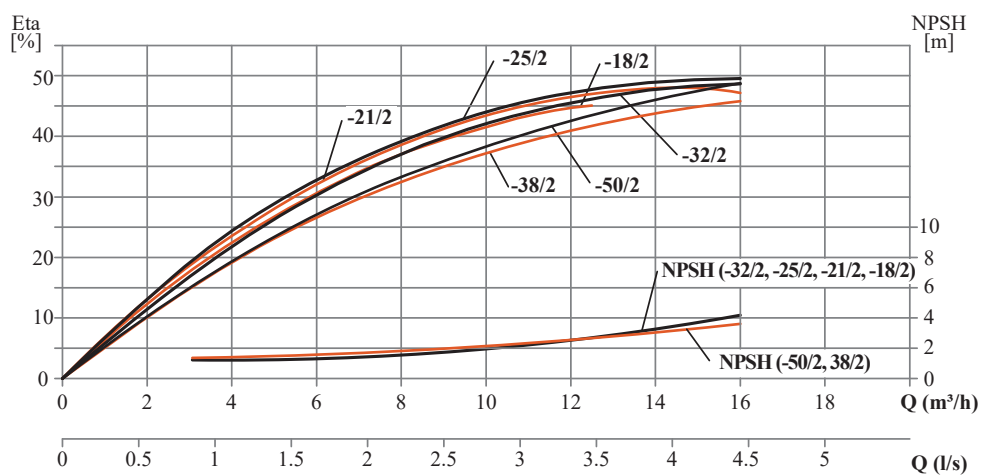
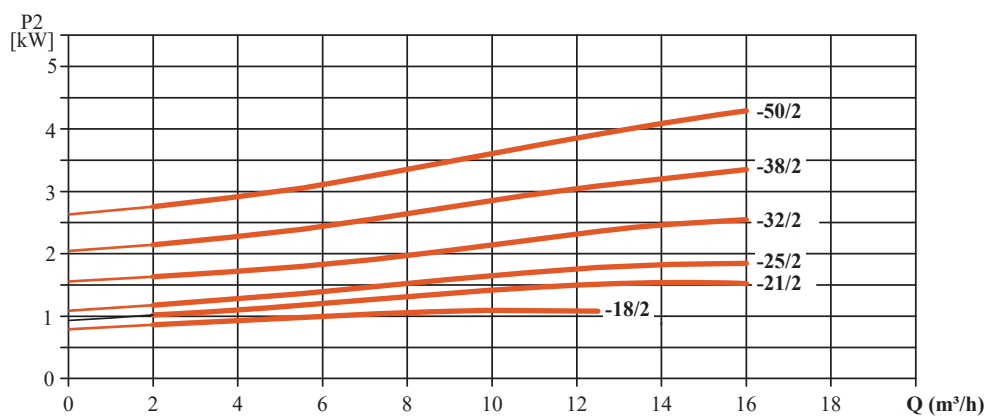
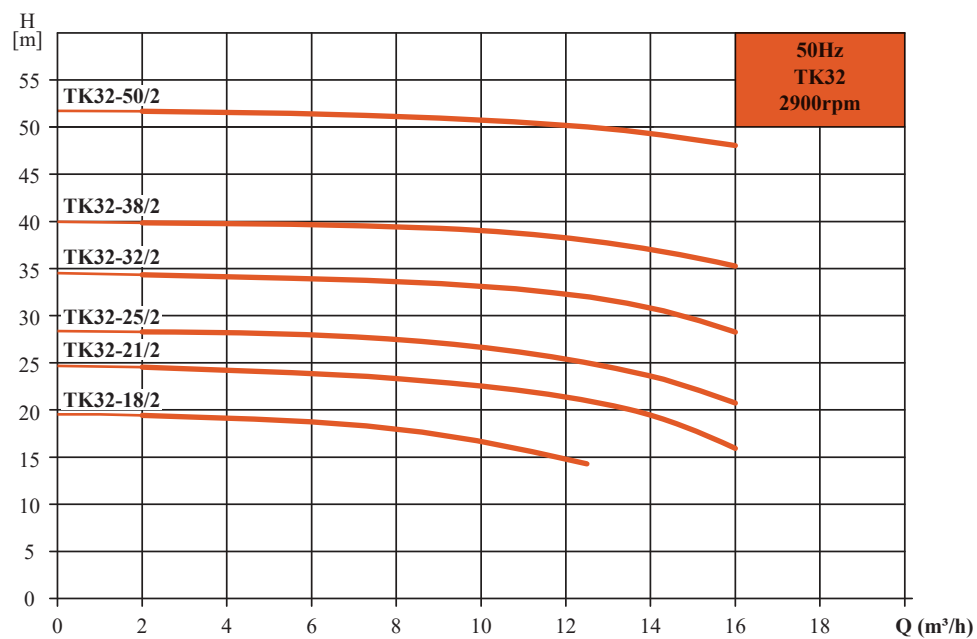

# TK40

## Performance data

Model	Power		Q (m <sup>3</sup> /h)	4	8	12.5	16	20	25	28	32
	kW	HP									
TK40-16/2	1.1	1.5	<b>H (m)</b>	17.7	17.3	16.0	12.5				
TK40-20/2	1.5	2.0		21.4	21.1	20.0	17.2				
TK40-18/2	2.2	3		19.8	19.8	19.5	19	18.0	15.8		
TK40-25/2	3	4		27.6	27.5	27.1	26.4	25.0	22.5		
TK40-30/2	4	5.5		33.7	33.6	33.1	32.6	31.7	30.0	28.6	26.0
TK40-36/2	5.5	7.5		38.9	38.8	38.5	38.1	37.3	36.0	35.0	32.5
TK40-48/2	7.5	10		49.7	49.7	49.5	49.4	49.0	48.0	46.6	44.1

## Installation dimensions & weight

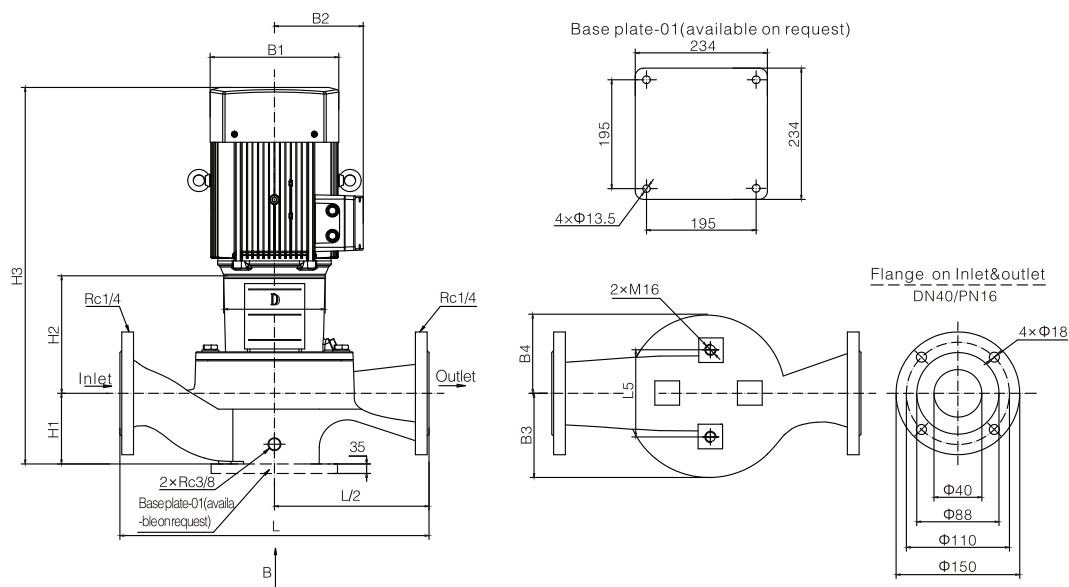

Model	Dimensions (mm)										Weight (kg)
	D	B1	B2	B3	B4	B5	H1	H2	H3	L	
TK40-16/2	120	170	142	96	95	120	68	178	497	320	31
TK40-20/2	140	190	155	96	95	120	68	188	549	320	36
TK40-18/2	140	190	155	109	94	144	100	195	588	340	40
TK40-25/2	160	197	165	126	114	144	100	207	621	340	52
TK40-30/2	160	230	188	126	114	144	100	207	642	340	62
TK40-36/2	200	260	208	136	123	144	110	227	747	440	86
TK40-48/2	200	260	208	136	123	144	110	227	747	440	95

## Performance curves

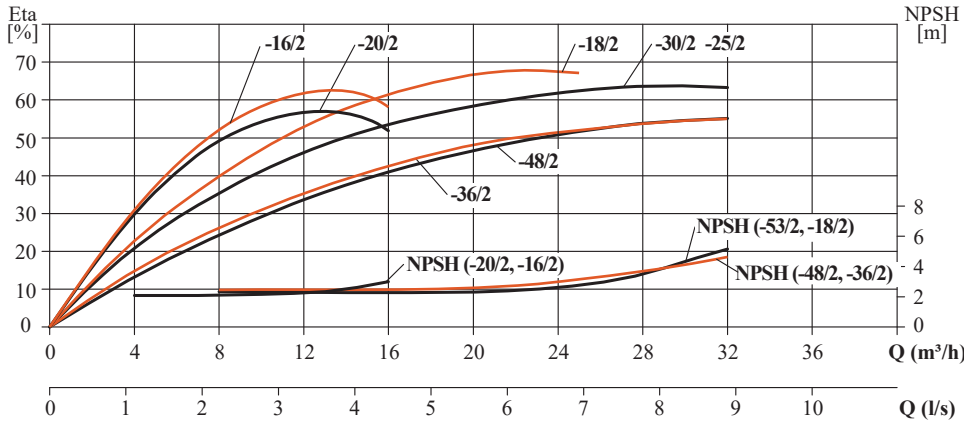
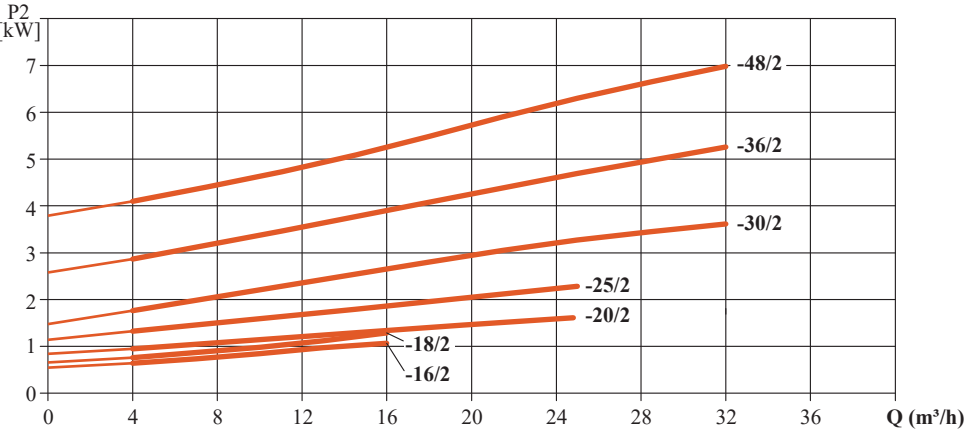
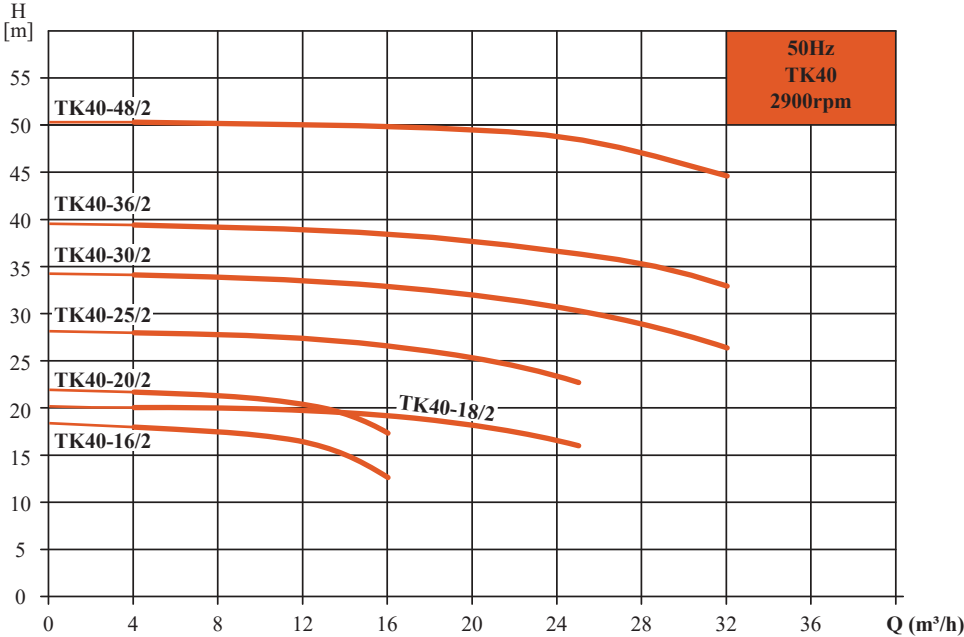

# TK50

1/2

## Performance data

Model	Power		Q (m <sup>3</sup> /h)	2.5	5	7.5	10	12.5	15	17.5	20
	kW	HP									
TK50-32/2	3	4	H (m)	34.9	34.6	34	33.2	32	30.5	27.9	23.2
TK50-38/2	4	5.5		40.7	40.6	40.2	39.2	38	36.2	33.9	30.3
TK50-48/2	5.5	7.5		50.4	50	49.7	49	48	46.5	44.2	40.6

## Installation dimensions & weight

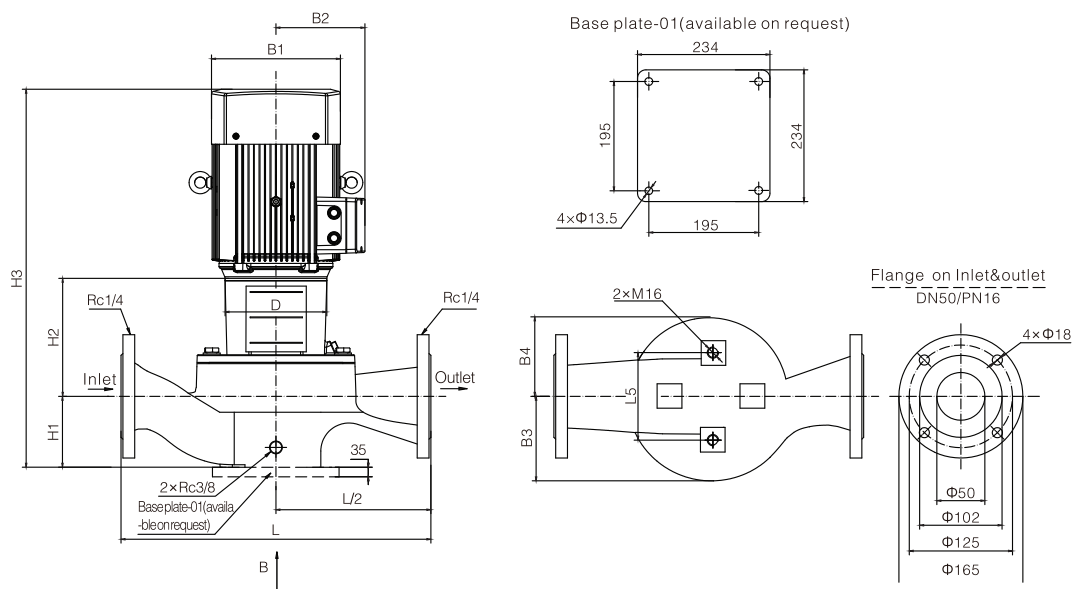

Model	Dimensions (mm)										Weight (kg)
	D	B1	B2	B3	B4	B5	H1	H2	H3	L	
TK50-32/2	160	197	165	127	127	144	105	181	600	400	58
TK50-38/2	160	230	188	127	127	144	105	181	621	400	68
TK50-48/2	200	260	208	127	127	144	105	201	716	400	85

## Performance curves

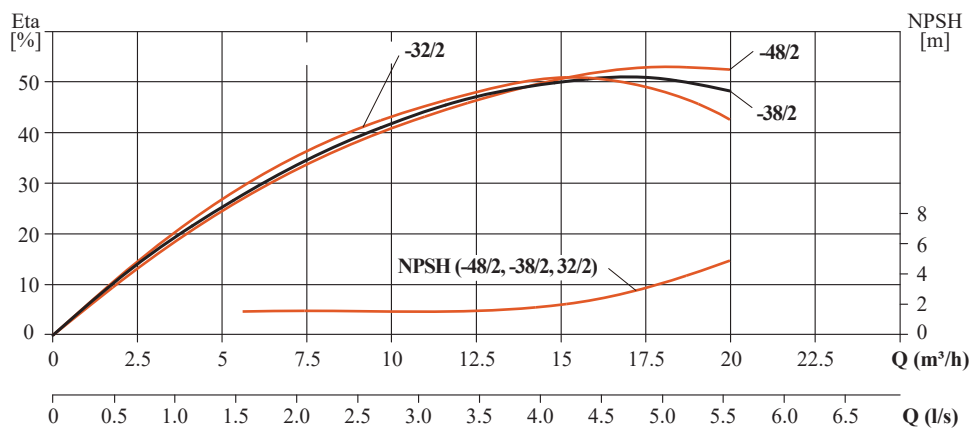
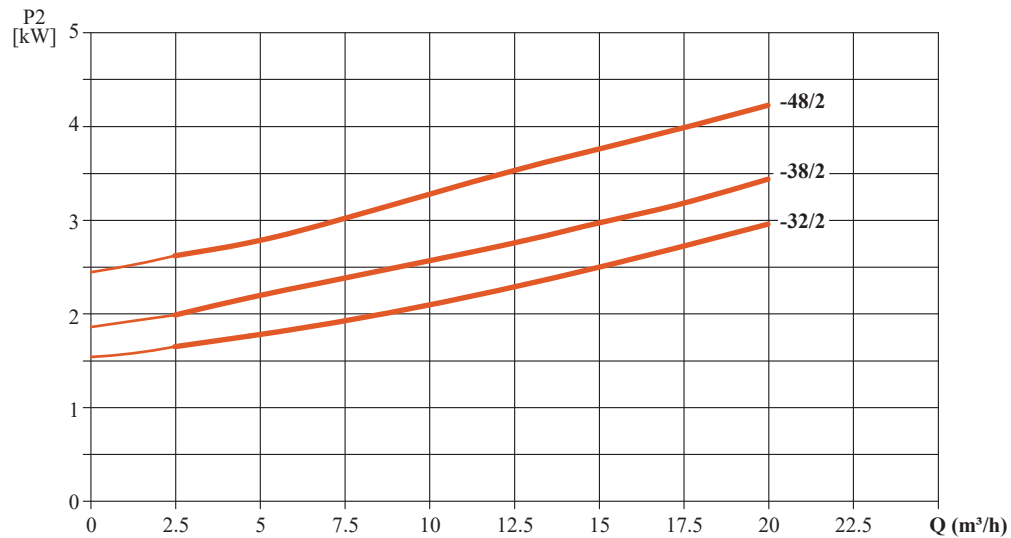
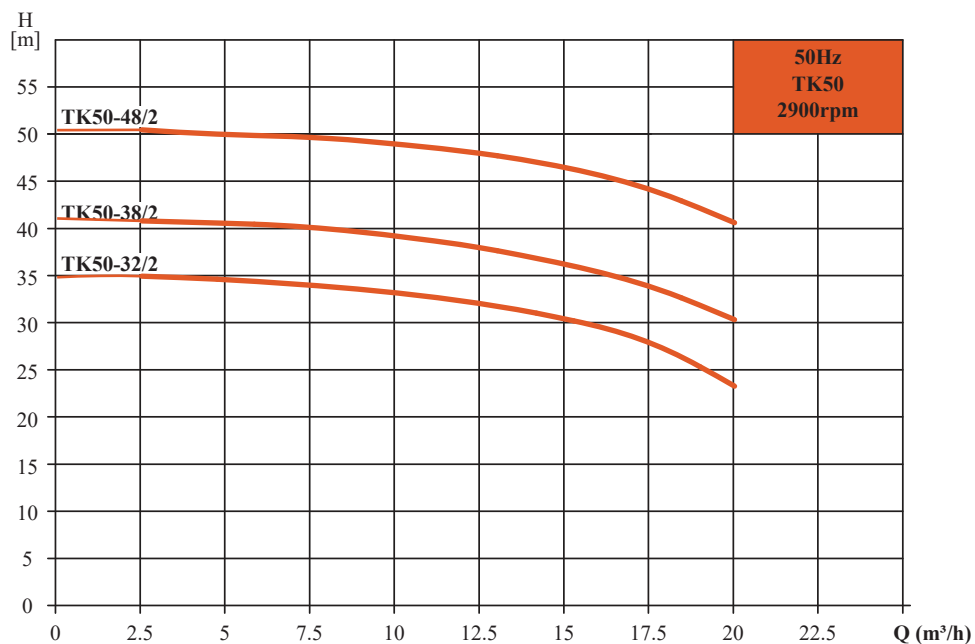



# TK50

2/2

## Performance data

Model	Power		Q (m <sup>3</sup> /h)	5	10	15	20	25	30	35	40	45	50	60
	kW	HP		H (m)										
TK50-12/2	1.1	1.5	H (m)	15.1	14.2	12	10							
TK50-15/2	1.5	2		18.8	18	16.5	15	12.6						
TK50-18/2	2.2	3		22.7	22.3	21	19.8	18	15					
TK50-24/2	3	4		26.1	26	25.5	25	24	22.3					
TK50-28/2	4	5.5		31.4	31.3	31	30.5	29.5	28	25.5				
TK50-35/2	5.5	7.5		36.8	36.7	36.5	36.2	35.8	35	33.7	31.5			
TK50-40/2	7.5	10		42.2	42.2	41.9	41.7	41.3	40.8	40	38.3	35		
TK50-50/2	11	15		53.4	53.4	53.1	52.9	52.5	51.9	51.1	50	48.4	45.8	
TK50-60/2	15	20		65.6	65.8	65.7	65.6	65.3	64.7	63.9	62.8	61.6	60	55.3
TK50-70/2	18.5	25		73.6	73.6	73.4	73.3	73.1	72.9	72.5	72	71.2	70	65.3
TK50-81/2	22	30		85.4	85.3	85	84.8	84.5	84	83.5	82.8	82.1	81	77

## Installation dimensions & weight

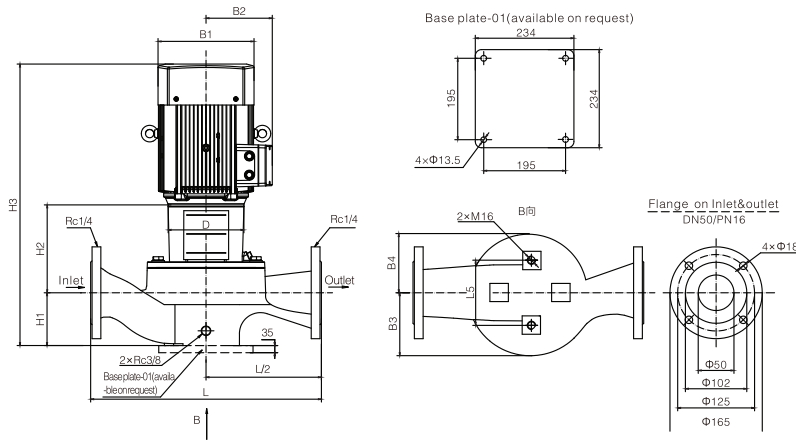

Model	Dimensions (mm)										Weight (kg)
	D	B1	B2	B3	B4	B5	H1	H2	H3	L	
TK50-12/2	120	170	142	116	114	144	105	174	530	340	36
TK50-15/2	140	190	155	116	114	144	105	174	572	340	42
TK50-18/2	140	190	155	116	114	144	105	174	572	340	44
TK50-24/2	160	197	165	116	114	144	105	184	603	340	50
TK50-28/2	160	230	188	128	114	144	115	198	648	340	64
TK50-35/2	200	260	208	128	114	144	115	218	742	340	83
TK50-40/2	200	260	208	170	157	144	115	215	740	440	98
TK50-50/2	350	330	255	170	157	144	115	245	902	440	172
TK50-60/2	350	330	255	170	157	144	115	245	935	440	182
TK50-70/2	350	330	255	170	157	144	115	245	935	440	196
TK50-81/2	350	360	280	170	157	144	115	245	965	440	238

## Performance curves

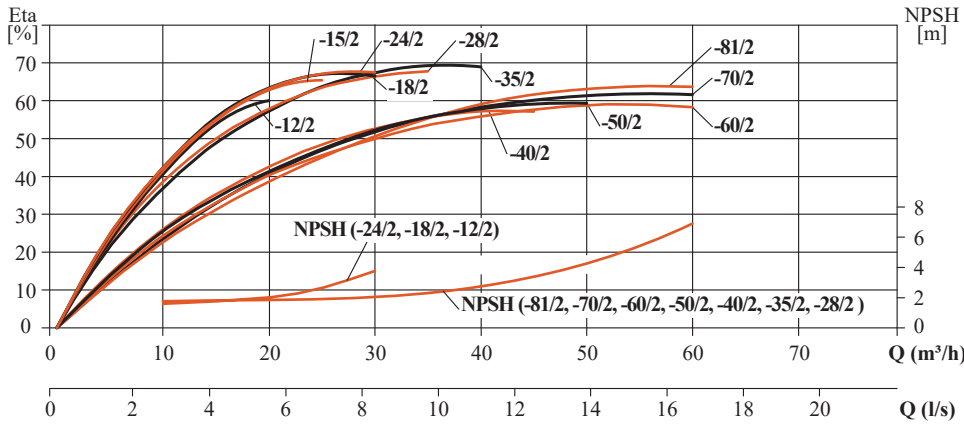
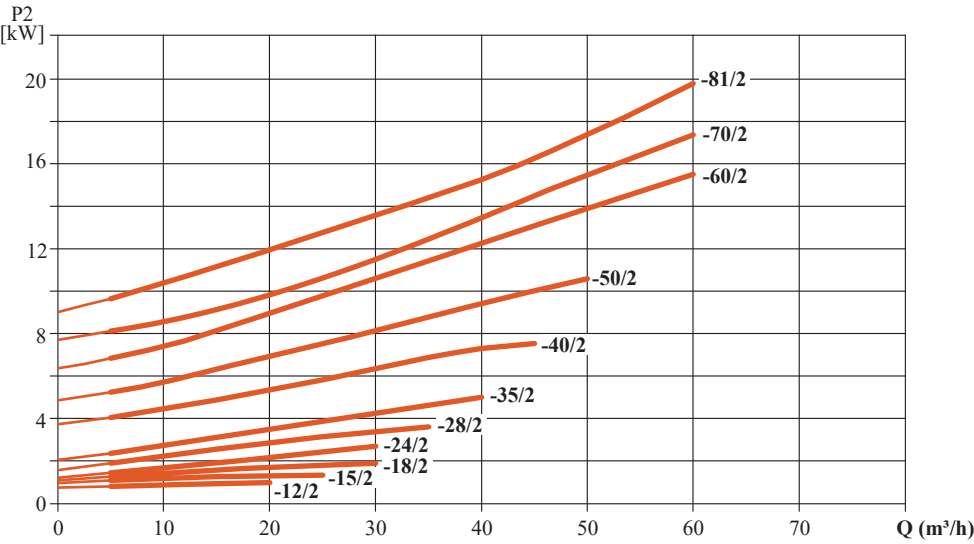
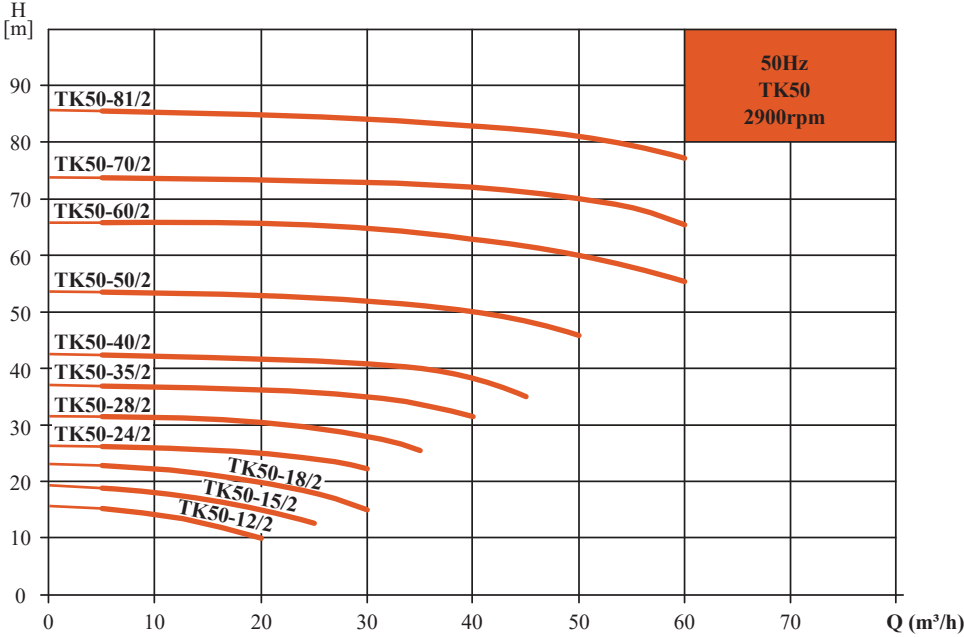

# TK65

1/2

## Performance data

Model	Power		Q (m <sup>3</sup> /h)	5	10	15	20	25	30	35
	kW	HP								
TK65-36/2	5.5	7.5	<b>H (m)</b>	39.1	39.1	38.9	38.2	36	31.8	24.7
TK65-48/2	7.5	10		50.3	50.3	50	49.3	48	45.9	42.4

## Installation dimensions & weight

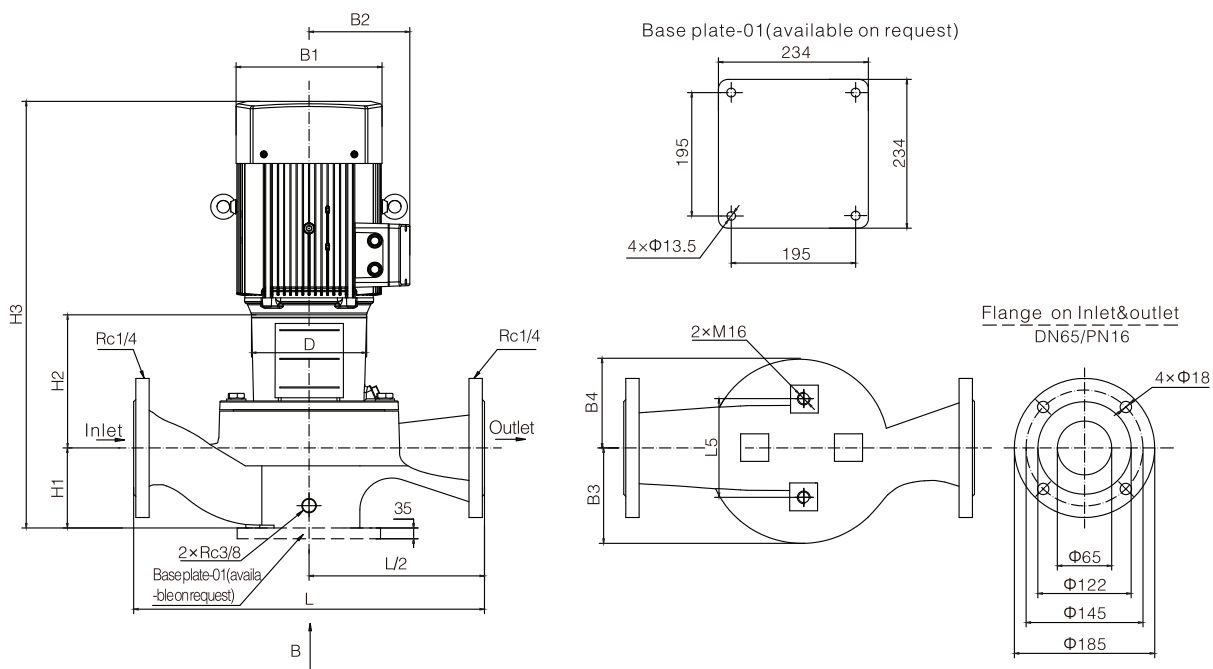

Model	Dimensions (mm)										Weight (kg)
	D	B1	B2	B3	B4	B5	H1	H2	H3	L	
TK65-36/2	200	260	208	127	127	144	105	209	724	400	87
TK65-48/2	200	260	208	127	127	144	105	209	724	400	94

## Performance curves

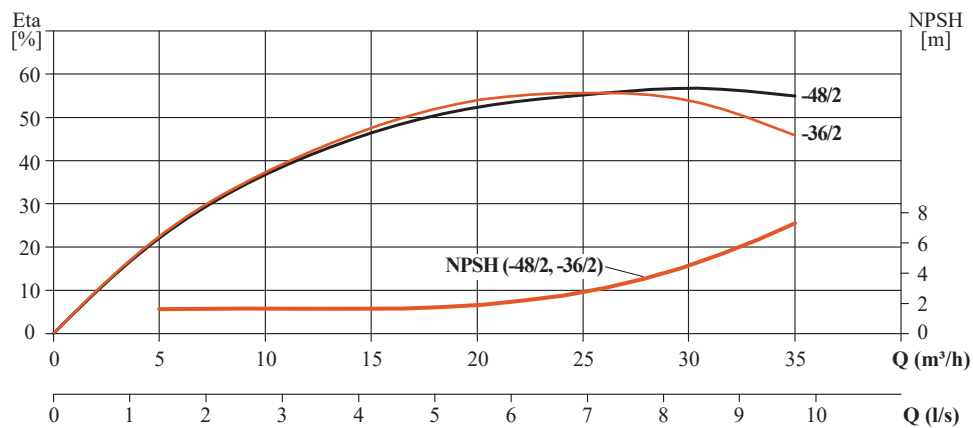
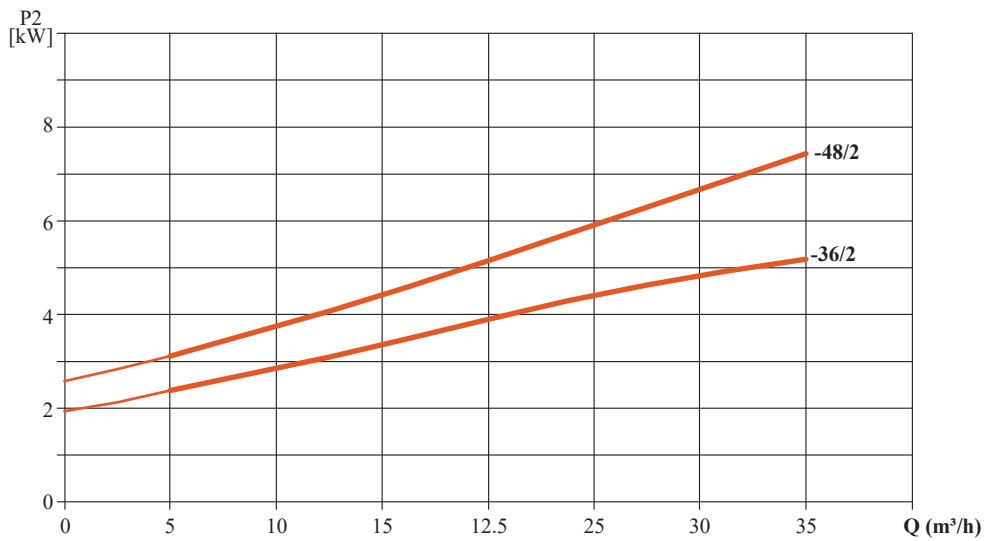
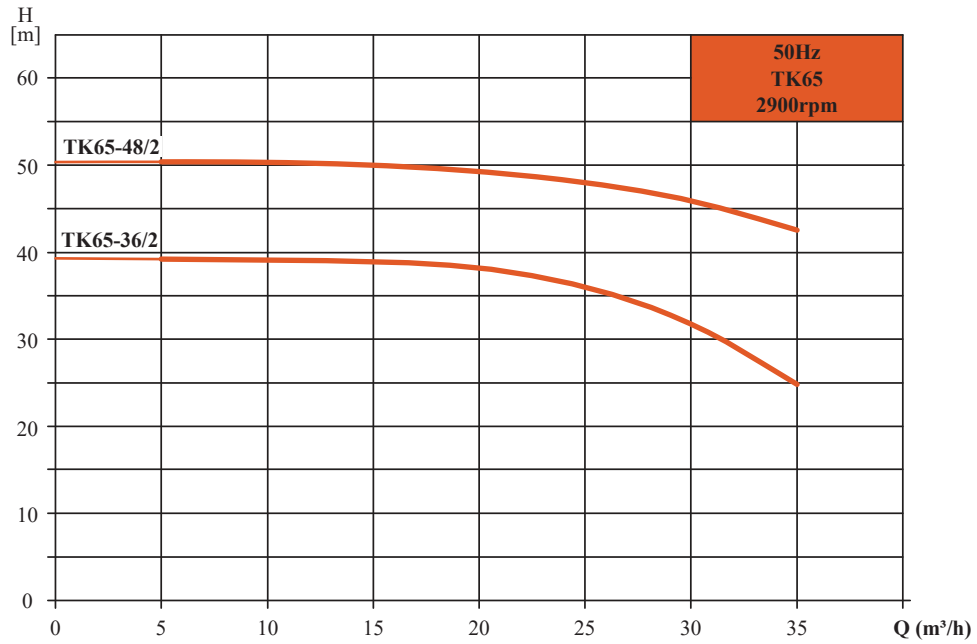

# TK65

2/2

## Performance data

Model	Power		Q (m <sup>3</sup> /h)	10	20	30	40	50	60	70	80	90
	kW	HP										
TK65-15/2	2.2	3	H	17.8	17	15	10.7					
TK65-19/2	3	4		21.6	20.8	19	15.2					
TK65-22/2	4	5.5		25	24.7	23.9	22	17.5				
TK65-30/2	5.5	7.5		32.3	32.1	31.5	30	26.1				
TK65-34/2	7.5	10		38.5	38.2	37.6	36.4	34	29.6			
TK65-40/2	11	15		43.3	42.9	42.3	41.4	40	37.6			
TK65-50/2	15	20		53.5	53.3	52.7	51.6	50	47.3			
TK65-61/2	18.5	25		63	63.2	63	62.3	61	58.8	54.8		
TK65-67/2	22	30		67.9	67.8	67.7	67.5	67	65.8	63.4	59.7	
TK65-83/2	30	40		85.3	85.1	84.6	83.9	83	81.7	80	77.8	74.1

## Installation dimensions & weight

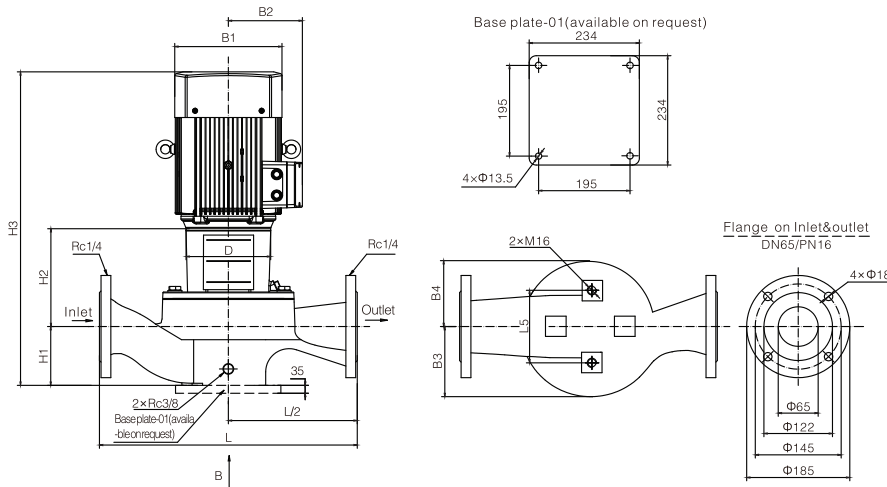

Model	Dimensions (mm)										Weight (kg)
	D	B1	B2	B3	B4	B5	H1	H2	H3	L	
TK65-15/2	140	190	155	141	123	144	105	193	591	360	48
TK65-19/2	160	197	165	141	123	144	105	203	622	360	57
TK65-22/2	160	230	188	141	123	144	105	203	643	360	65
TK65-30/2	200	260	208	141	123	144	105	223	738	360	84
TK65-34/2	200	260	208	141	123	144	105	223	738	360	91
TK65-40/2	350	330	255	177	165	144	125	257	924	475	178
TK65-50/2	350	330	255	177	165	144	125	257	957	475	190
TK65-61/2	350	330	255	177	165	144	125	257	957	475	202
TK65-67/2	350	330	280	177	165	144	125	257	987	475	242
TK65-83/2	400	400	305	177	165	144	125	257	1047	475	298

## Performance curves

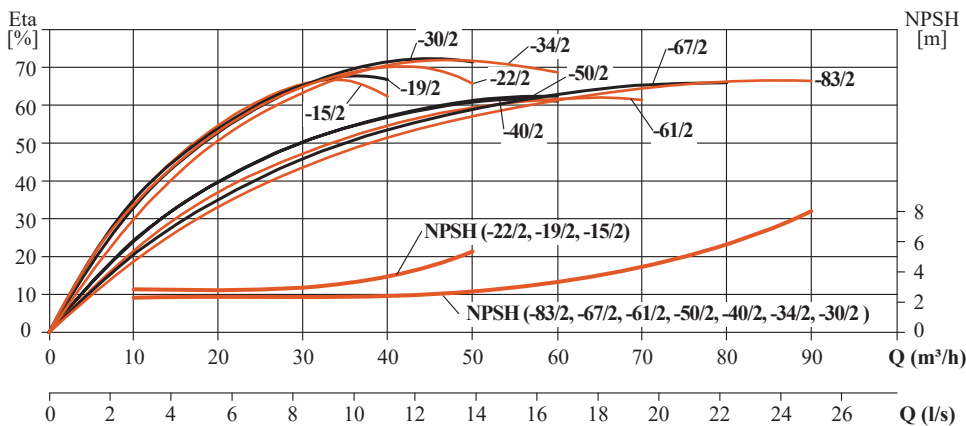
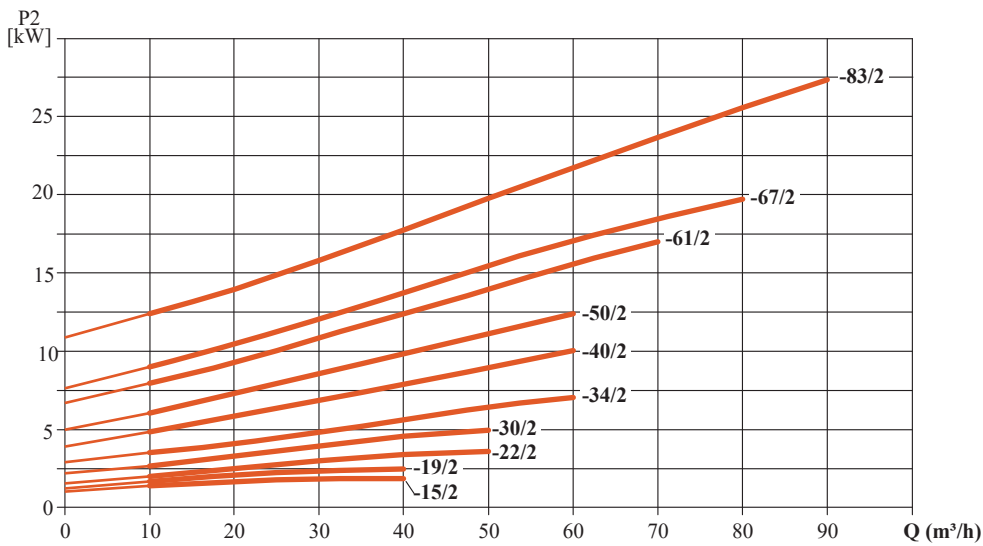
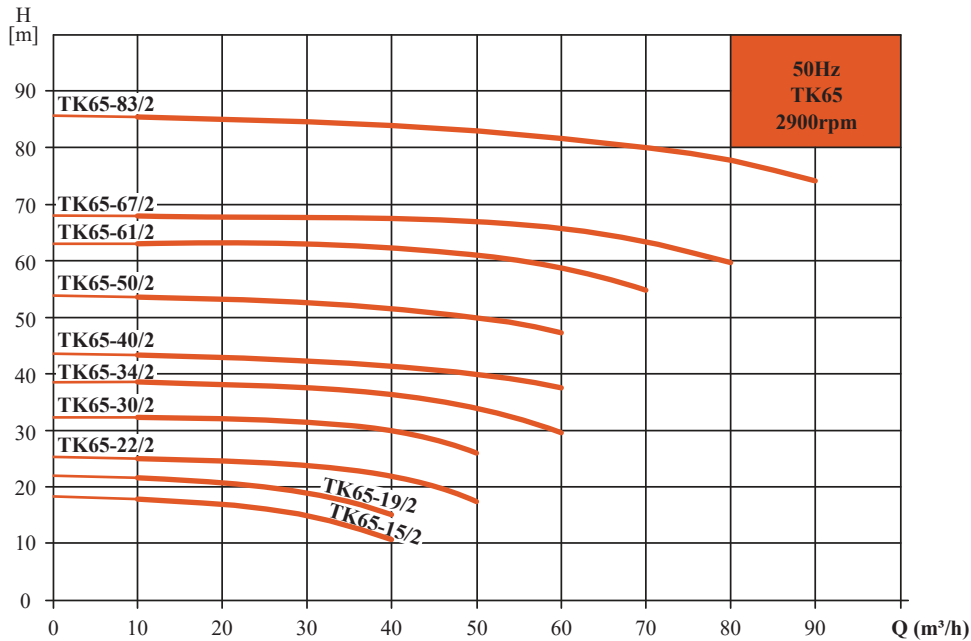

# TK80

1/2

## Performance data

Model	Power		Q (m <sup>3</sup> /h)	10	20	30	40	50	60	65
	kW	HP		H (m)						
TK80-40/2	11	15	<b>H</b>	42.7	42.8	42.7	41.8	40	36.5	
TK80-48/2	15	20		50.3	50.4	50.2	49.5	48	45	42.5

## Installation dimensions & weight

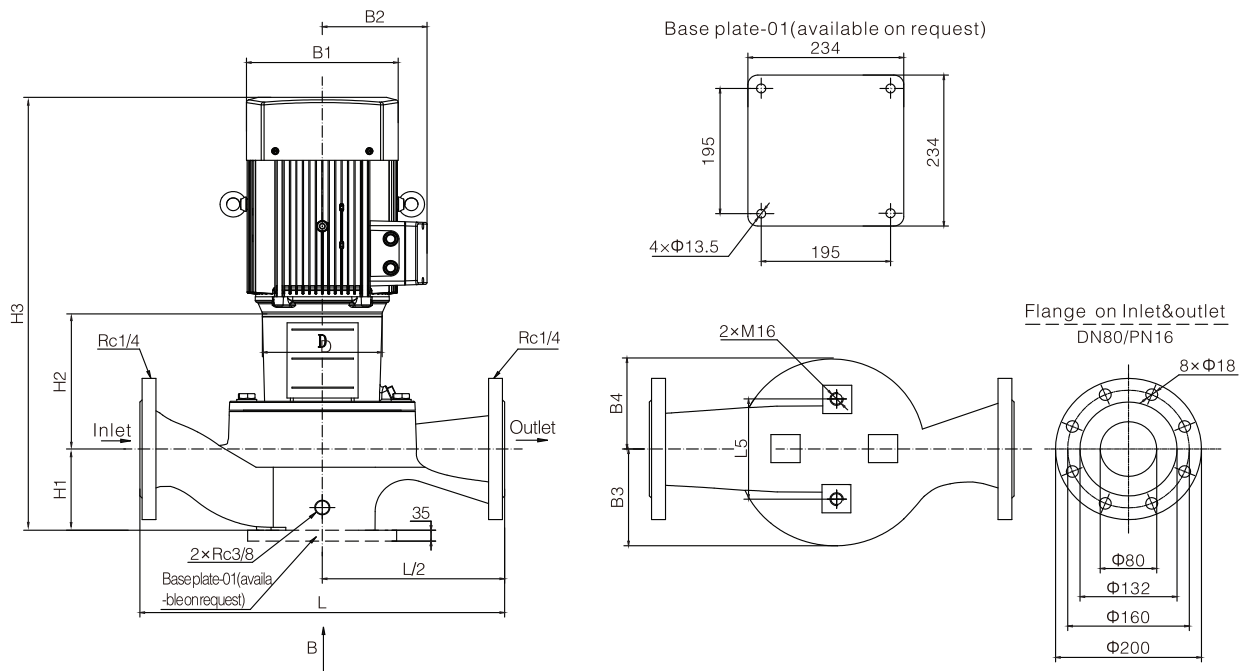

Model	Dimensions (mm)										Weight (kg)
	D	B1	B2	B3	B4	B5	H1	H2	H3	L	
TK80-40/2	350	330	255	136	127	144	115	235	892	500	172
TK80-48/2	350	330	255	136	127	144	115	235	925	500	183



Performance curves

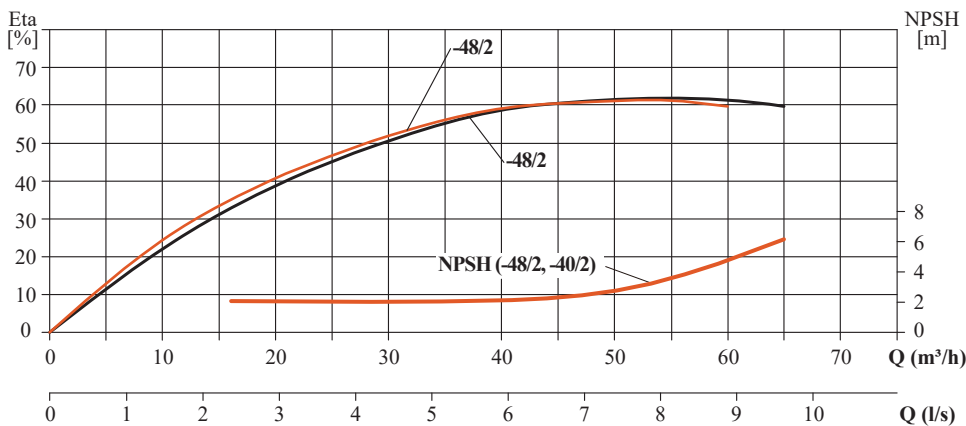
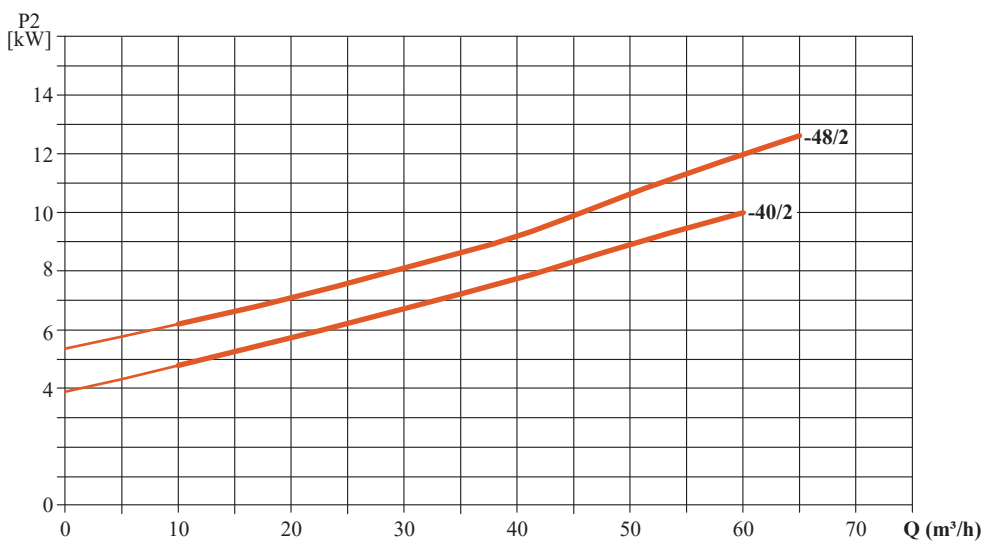
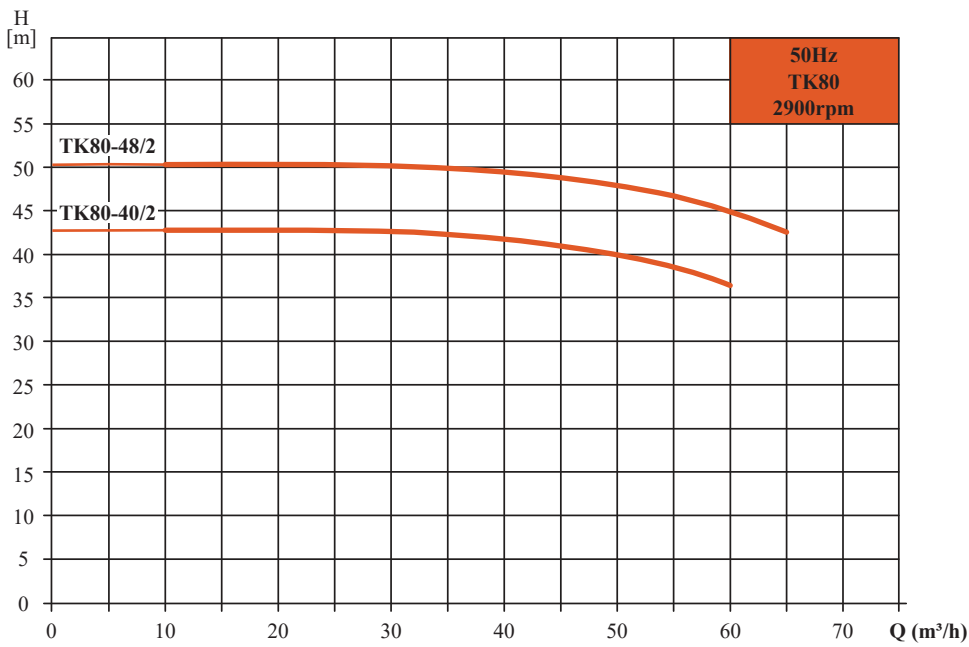

# TK100

## Performance data

Model	Power		Q (m <sup>3</sup> /h)	H (m)															
	kW	HP		10	20	30	40	50	60	70	80	90	100	110	120	130	145	160	
TK100-9/2	2.2	3	H	13.8	13.2	12.2	10.8	9	6.8	4.4									
TK100-15/2	4	5.5		18.5	18.2	17.7	17.1	16.2	15	13.4	11								
TK100-17/2	5.5	7.5		21.6	21.5	21.1	20.7	20	19.2	18.3	17	15.3	13	10.4					
TK100-22/2	7.5	10		26.7	26.6	26.3	25.9	25.3	24.5	23.4	22	20.3	18.2	15.8					
TK100-27/2	11	15		31.4	31.3	31.1	30.9	30.7	30.3	29.8	29.2	28.2	27	25.5	23.6	20.8			
TK100-33/2	15	20		37	37	36.8	36.6	36.2	35.8	35.3	34.7	33.9	33	31.7	30.1	27.9			
TK100-40/2	18.5	25		43.2	43.2	43.1	42.9	42.7	42.4	42.1	41.6	40.9	40	38.9	37.4	35.3			
TK100-48/2	22	30		51.1	51.1	51	50.8	50.6	50.3	49.9	49.4	48.8	48	46.9	45.3	43.2			
TK100-52/2	30	40		55.2	55.3	55.3	55.3	55.2	55.1	54.8	54.6	54.4	54.2	53.8	53.1	52	49	43.4	

## Installation dimensions & weight

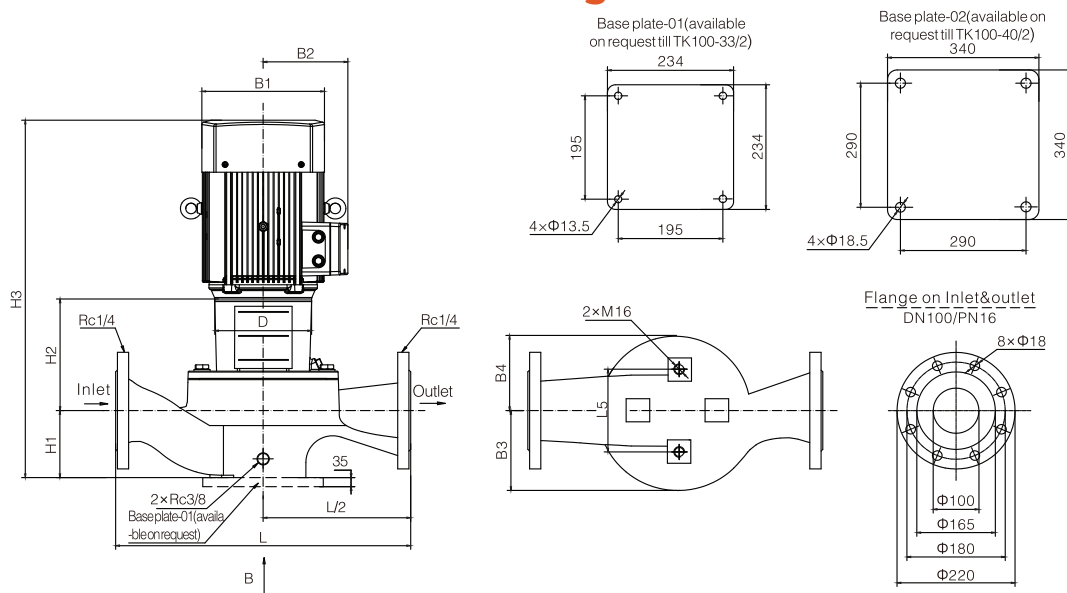

Model	Dimensions (mm)										Weight (kg)
	D	B1	B2	B3	B4	B5	H1	H2	H3	L	
TK100-9/2	140	175	155	132	99	160	105	211	609	450	54
TK100-15/2	160	215	190	132	99	160	105	212	652	450	70
TK100-17/2	200	260	205	148	115	144	140	237	787	500	98
TK100-22/2	200	260	205	148	115	144	140	237	787	500	106
TK100-27/2	350	350	255	145	121	144	140	252	934	550	184
TK100-33/2	350	350	255	145	121	144	140	252	967	550	194
TK100-40/2	350	350	255	179	150	230	140	266	981	550	216
TK100-48/2	350	350	280	179	150	230	140	266	1011	550	258
TK100-52/2	400	400	305	179	150	230	140	266	1071	550	312

## Performance curves

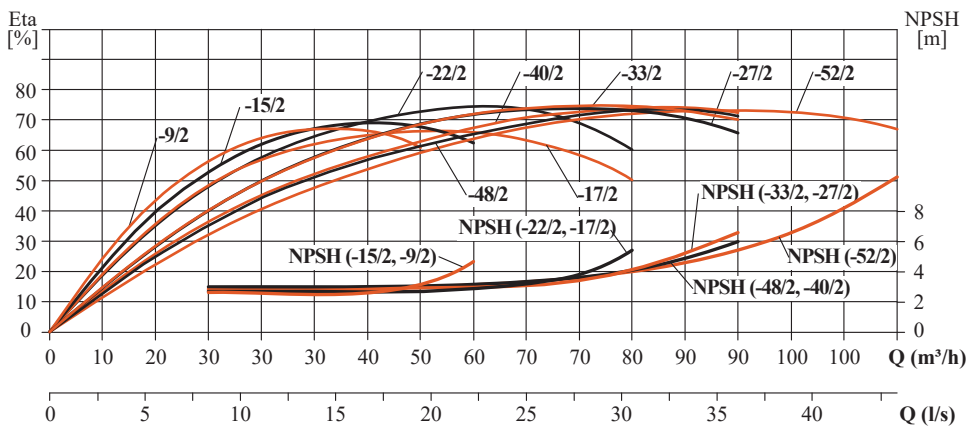
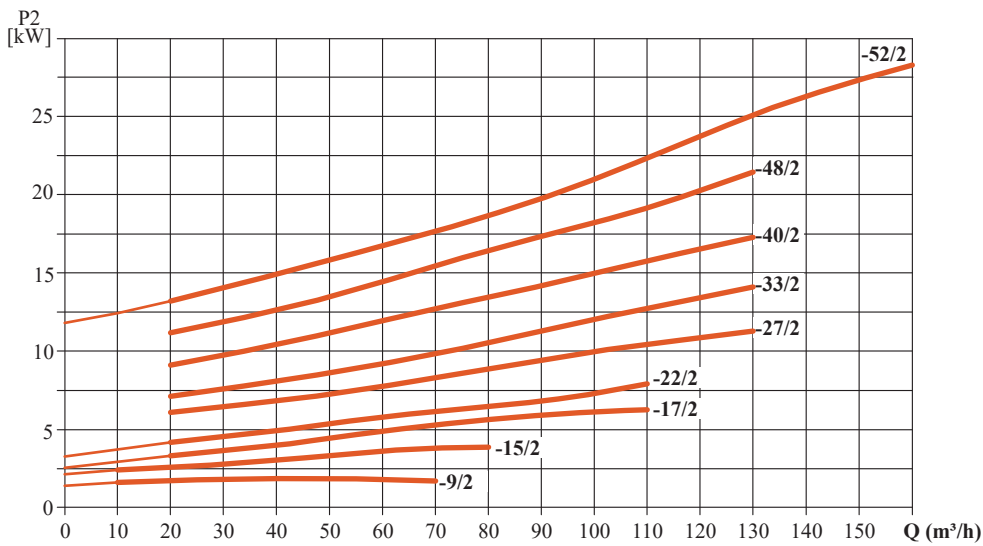
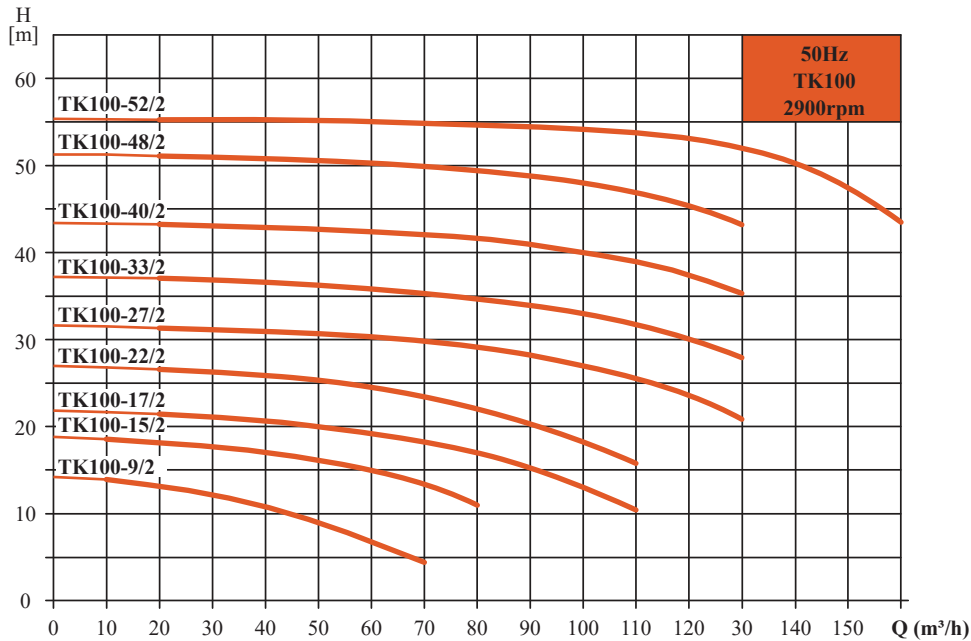

# TK125

## Performance data

Model	Power		Q (m <sup>3</sup> /h)	40	60	80	100	120	140	160	180	200
	kW	HP										
TK125-11/4	5.5	7.5	<b>H (m)</b>	12.8	12.7	12.4	11.8	11	9.9	8		
TK125-14/4	7.5	10		16.1	15.9	15.5	14.9	14	12.8	11.2		
TK125-18/4	11	15		21.4	21.3	21	20.6	19.9	19.1	18	16.4	14
TK125-22/4	15	20		26.6	26.5	26.2	25.7	24.9	23.7	22	19.8	16.6
TK125-28/4	18.5	25		30.8	30.8	30.7	30.5	30.1	29.3	28	25.8	22.1
TK125-32/4	22	30		34.6	34.6	34.5	34.4	34	33.3	32	30.2	27.2
TK125-40/4	30	40		43.8	43.6	43.3	42.9	42.2	41.3	40	38	35.3
TK125-48/4	37	50		51.4	51.3	51	50.5	49.9	49.1	48	46.4	44.1

## Installation dimensions & weight

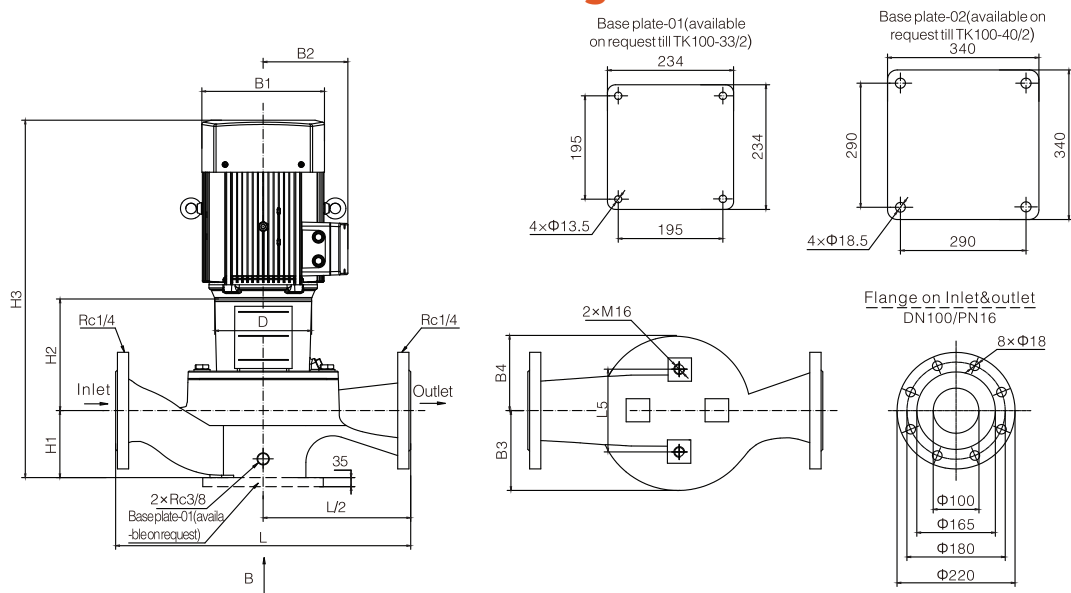

Model	Dimensions (mm)										Weight (kg)
	D	B1	B2	B3	B4	B5	H1	H2	H3	L	
TK125-11/4	200	260	208	215	175	230	215	256	887	620	142
TK125-14/4	200	260	208	215	175	230	215	256	887	620	152
TK125-18/4	350	330	255	210	176	230	215	297	1054	800	258
TK125-22/4	350	330	255	235	207	230	215	297	1087	800	310
TK125-28/4	350	330	280	235	207	230	215	316	1106	800	350
TK125-32/4	350	330	280	235	207	230	215	316	1136	800	376
TK125-40/4	400	400	305	271	247	230	215	323	1238	800	462
TK125-48/4	450	450	335	271	247	230	215	323	1243	800	518

## Performance curves

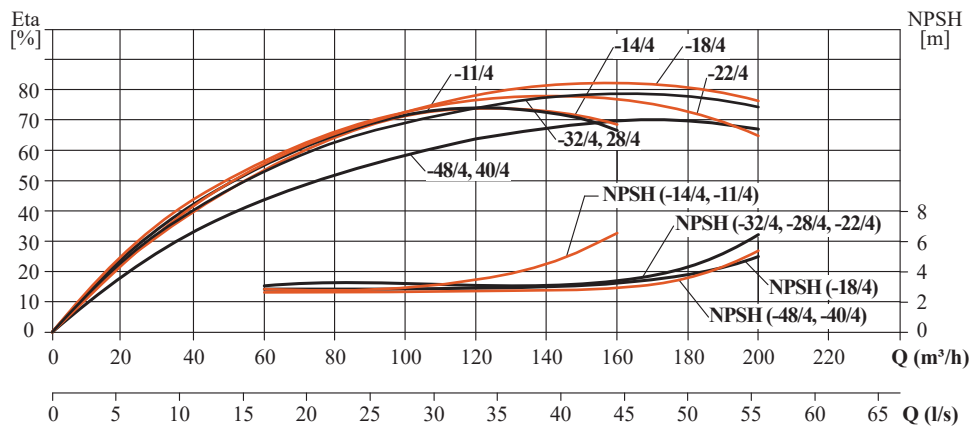
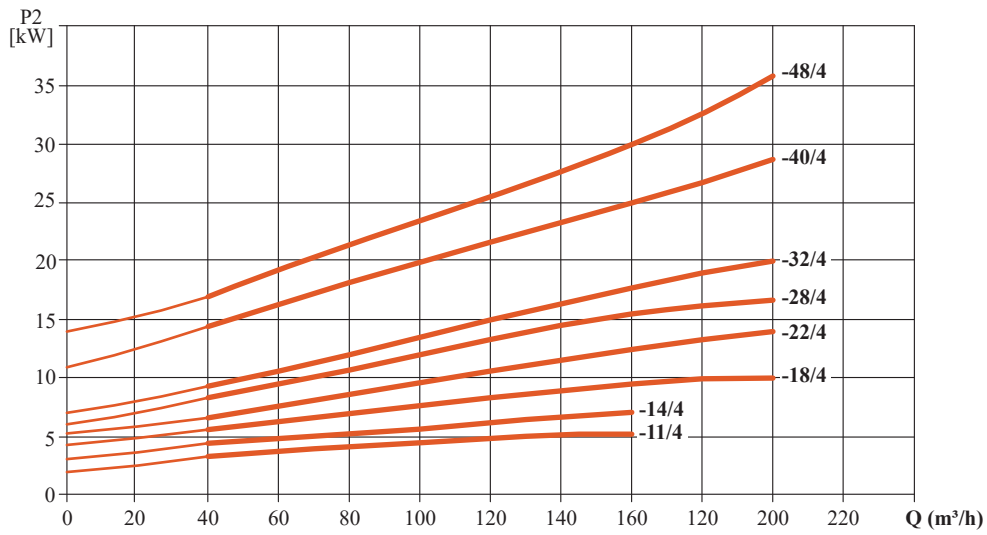
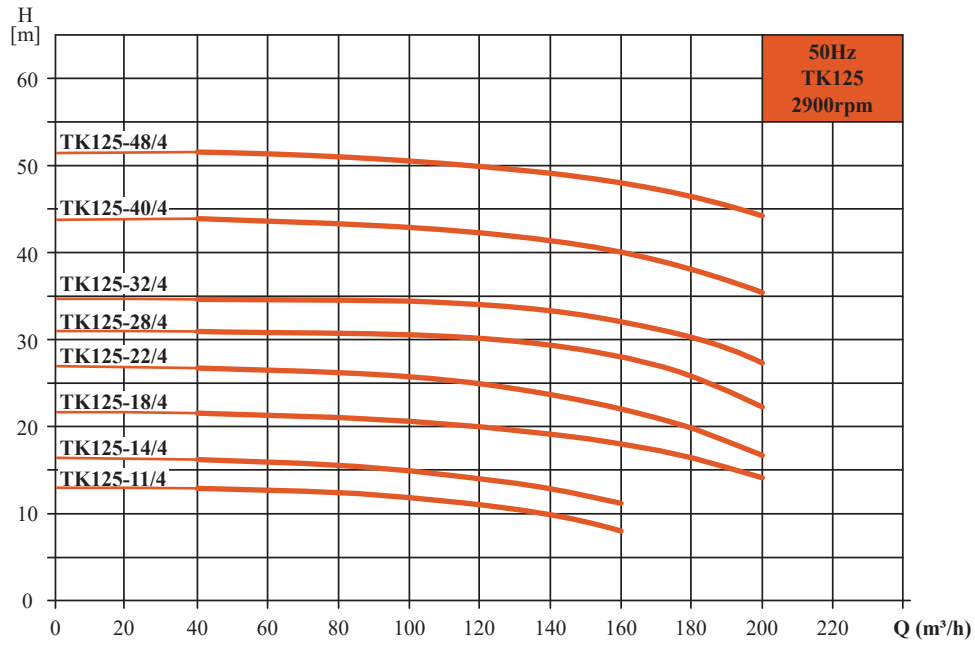

# TK150

## Performance data

Model	Power		Q (m <sup>3</sup> /h)	50	80	110	140	170	200	220	240
	kW	HP		H (m)							
TK150-12.5/4	11	15		14.5	14.5	14.4	14.2	13.7	12.5	11.1	9.1
TK150-17/4	15	20		18.7	18.8	18.7	18.5	18	17	16.1	14.9
TK150-21/4	18.5	25		23.2	23.1	22.9	22.6	22	21	19.8	17.8
TK150-25/4	22	30		27.9	28	27.8	27.3	26.5	25	23.5	21.2
TK150-33/4	30	40		35.4	35.4	35.2	34.8	34.2	33	31.5	29.5
TK150-40/4	37	50		43	43	42.8	42.4	41.6	40	38.4	36.1
TK150-50/4	45	60		52.3	52.2	52	51.7	51.1	50	48.7	46.6

## Installation dimensions & weight

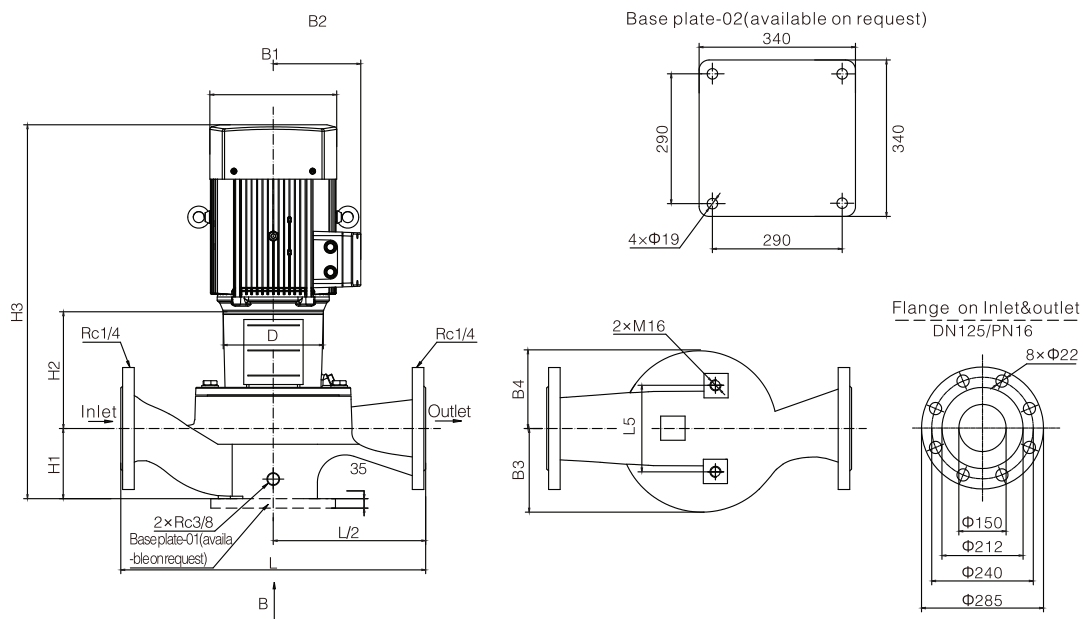

Model	Dimensions (mm)										Weight (kg)
	D	B1	B2	B3	B4	B5	H1	H2	H3	L	
TK150-12.5/4	350	315	255	216	179	230	215	293	1050	800	260
TK150-17/4	350	315	255	216	179	230	215	293	1083	800	276
TK150-21/4	350	360	280	216	179	230	215	293	1083	800	314
TK150-25/4	350	360	280	237	207	230	215	293	1113	800	372
TK150-33/4	400	400	305	237	207	230	215	293	1208	800	430
TK150-40/4	450	450	335	266	247	230	230	323	1258	900	432
TK150-50/4	450	450	335	266	247	230	230	323	1283	900	556

## Performance curves

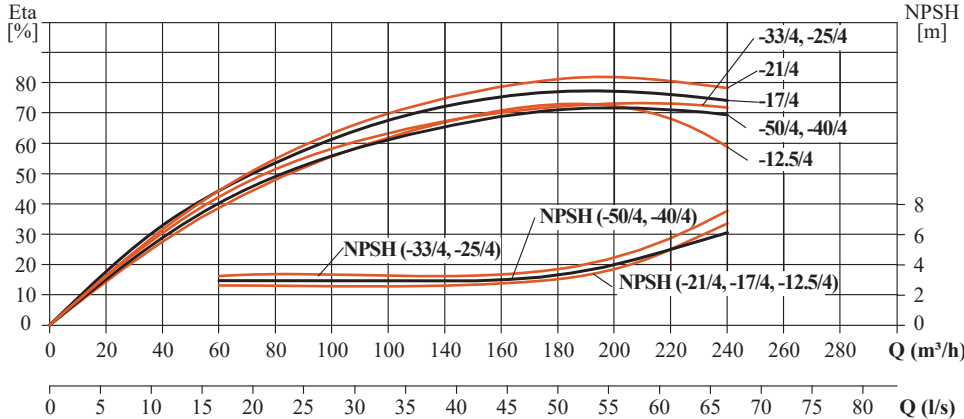
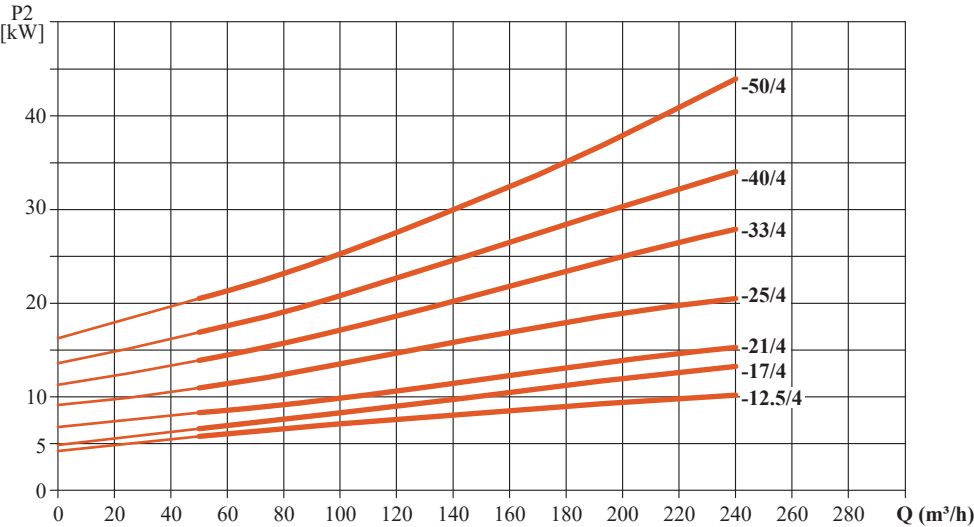
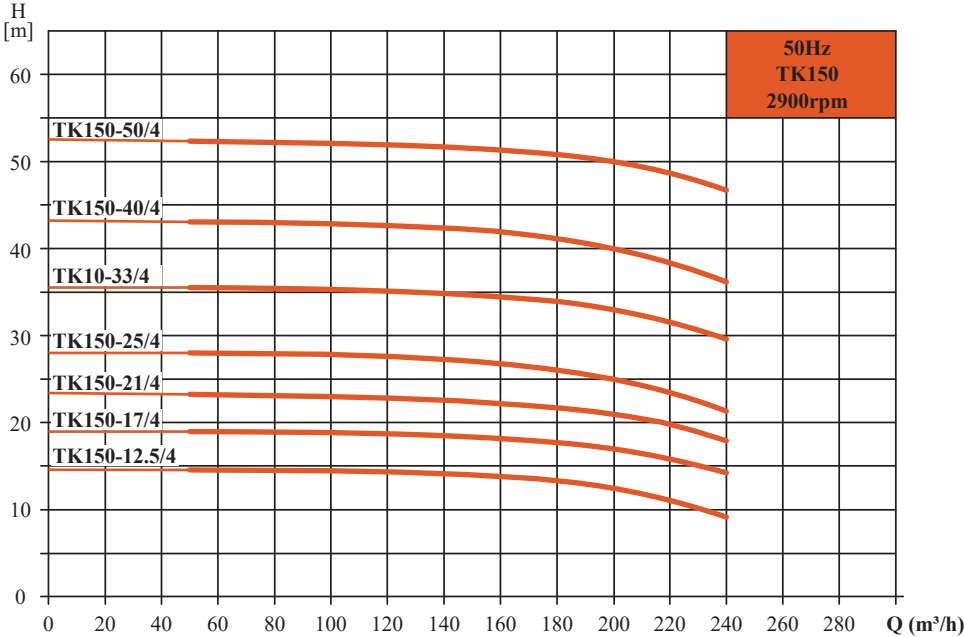



# TK200

1/2

## Performance data

Model	Power		Q (m <sup>3</sup> /h)	90	120	150	180	210	240	270	300	330	360
	kW	HP											
TK200-15/4	18.5	25	H (m)	17.9	17.7	17.5	17.2	16.8	16.4	15.8	15	14.1	12.8
TK200-18/4	22	30		20.9	20.7	20.5	20.2	19.8	19.8	18.8	18	17.1	15.7
TK200-24/4	30	40		26	26	25.8	25.7	25.4	25.1	24.6	24	23.1	21.8
TK200-30/4	37	50		33.3	33.2	33	32.6	32.2	31.6	30.9	30	29	27.6
TK200-35/4	45	60		38.2	38.3	38.3	37.8	37.3	36.7	35.9	35	33.8	32.1
TK200-44/4	55	75		46.2	46.1	45.9	45.6	45.4	45	44.6	44	43.1	41.8
TK200-53/4	75	100		55.6	55.7	55.7	55.5	55.3	54.8	54	53	51.6	49.9

## Installation dimensions & weight

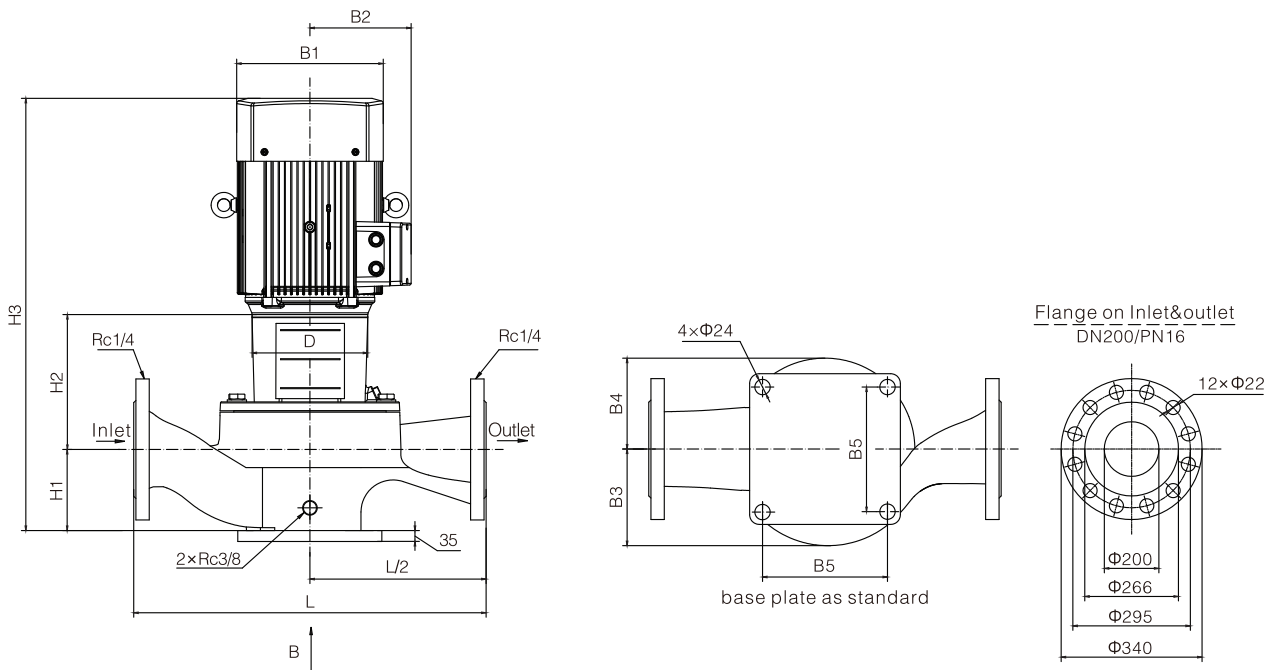

Model	Dimensions (mm)										Weight (kg)
	D	B1	B2	B3	B4	B5	H1	H2	H3	L	
TK200-15/4	350	360	280	277	218	360	270	343	1188	1000	420
TK200-18/4	350	360	280	277	218	360	270	343	1218	1000	440
TK200-24/4	400	400	305	302	251	360	270	343	1313	1100	538
TK200-30/4	450	450	335	302	251	360	270	373	1348	1100	590
TK200-35/4	450	450	335	302	251	360	270	373	1373	1100	630
TK200-44/4	550	490	370	314	268	360	270	388	1423	1100	768
TK200-53/4	550	550	410	314	268	360	270	388	1486	1100	902

## Performance curves

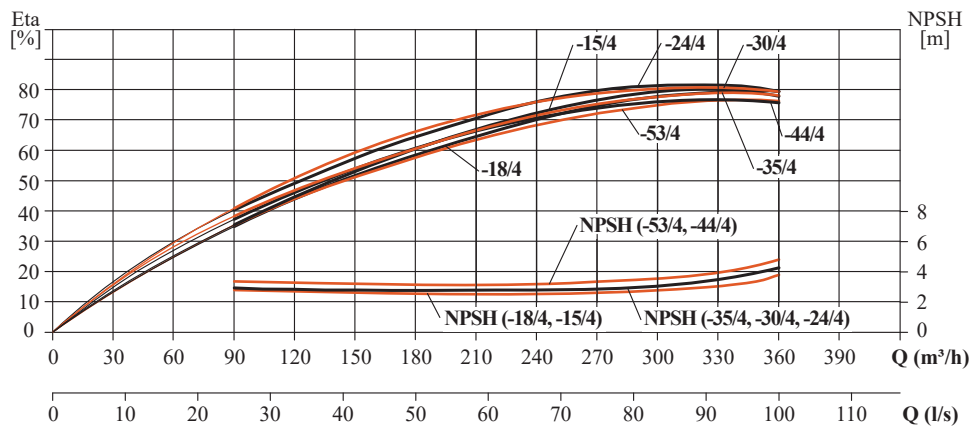
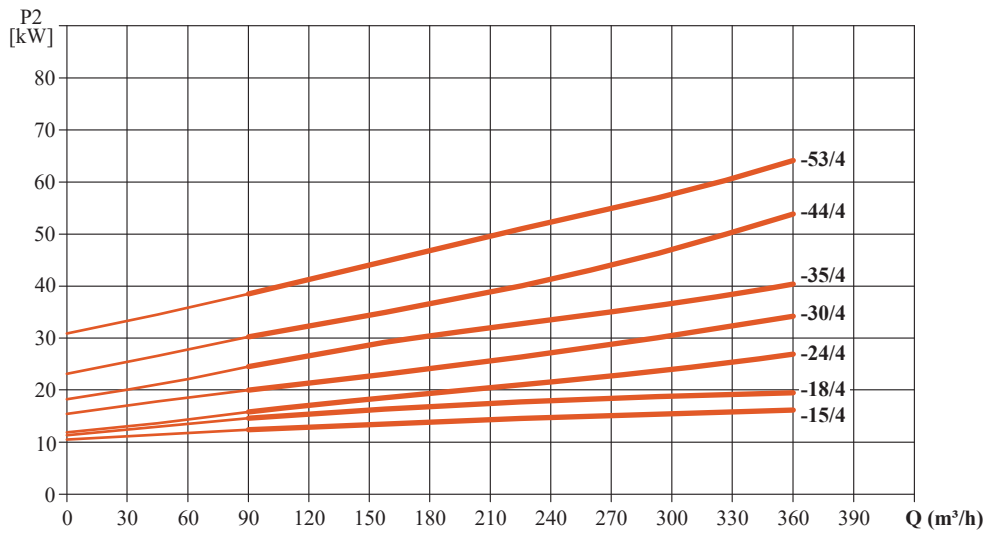
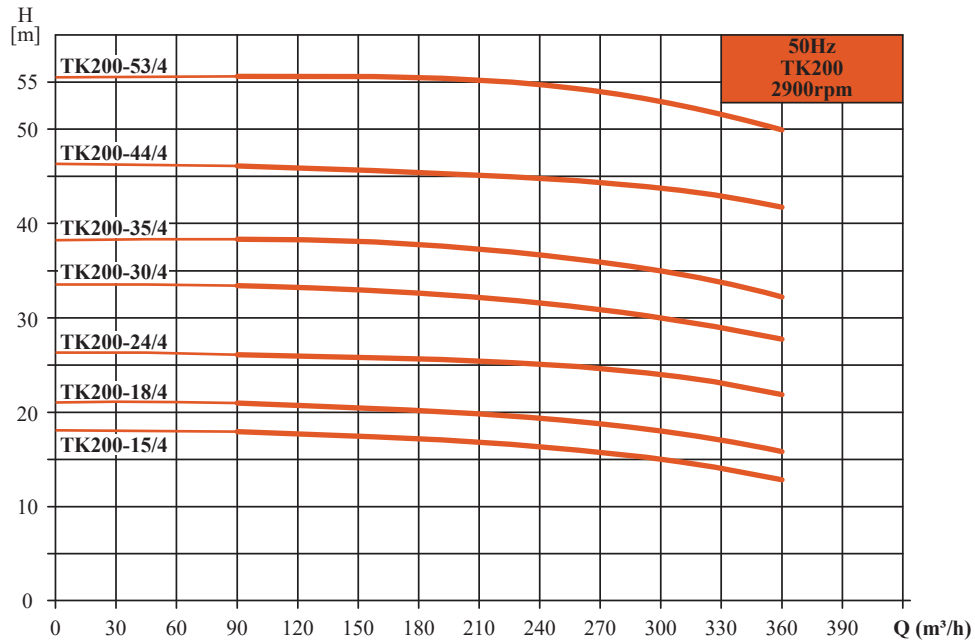

# TK200

2/2

## Performance data

Model	Power		Q (m <sup>3</sup> /h)	160	200	240	280	320	360	400	440	480
	kW	HP										
TK200-12.5/4	22	30	H (m)	17.1	16.9	16.5	15.9	15.1	14	12.5	10.7	7.9
TK200-20/4	30	40		24.5	24.4	24	23.6	22.8	21.7	20	17.5	14.1
TK200-23/4	37	50		28	27.8	27.4	26.8	25.9	24.8	23	20.9	18.1
TK200-27/4	45	60		32	31.7	31.2	30.5	29.6	28.4	27	24.9	22.4
TK200-32/4	55	75		37.4	37.1	36.5	35.7	34.7	33.3	32	29.9	27.6
TK200-43/4	75	100		46.9	46.7	46.4	45.9	45.3	44.4	43	41.1	38.5
TK200-50/4	90	120		52.8	52.8	52.6	52.2	51.7	51	50	48.3	45.4

## Installation dimensions & weight

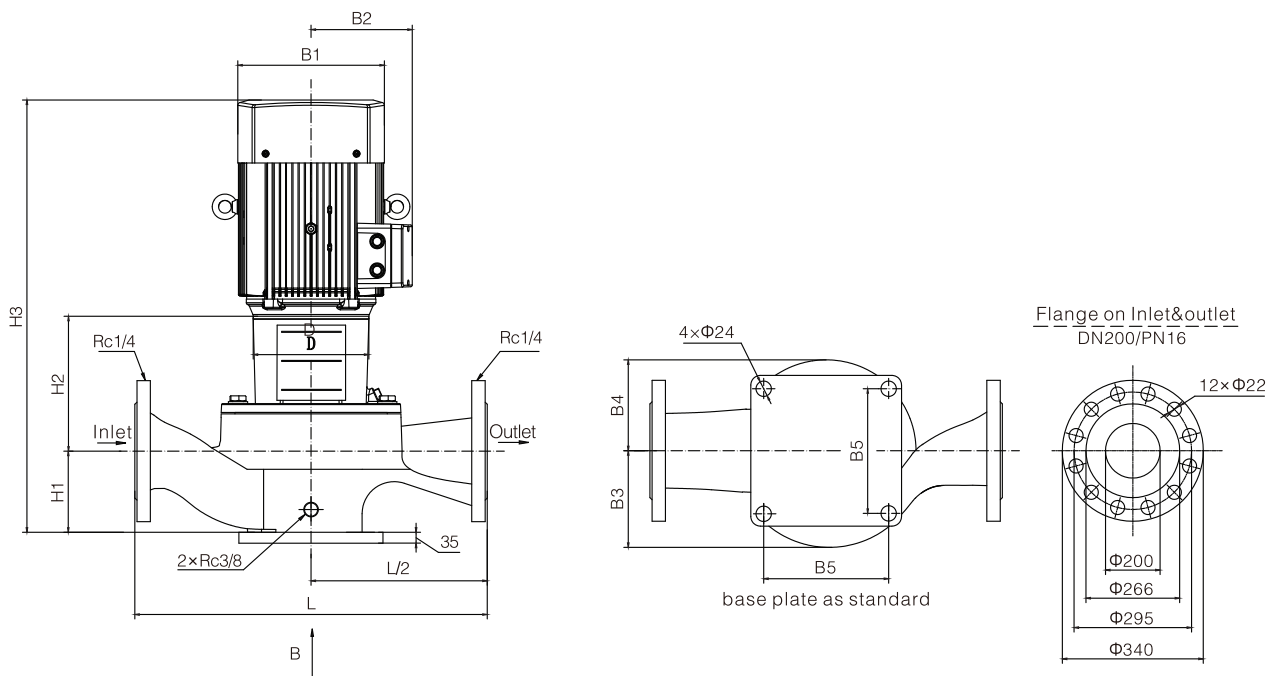

Model	Dimensions (mm)										Weight (kg)
	D	B1	B2	B3	B4	B5	H1	H2	H3	L	
TK200-12.5/4	350	360	280	277	218	360	270	343	1218	1000	440
TK200-20/4	400	400	305	277	218	360	270	343	1313	1000	506
TK200-23/4	450	450	335	302	251	360	270	373	1348	1100	589
TK200-27/4	450	450	335	302	251	360	270	373	1373	1100	630
TK200-32/4	550	490	370	302	251	360	270	373	1408	1100	720
TK200-43/4	550	550	410	314	268	360	270	388	1486	1100	900
TK200-50/4	550	550	410	314	268	360	270	388	1538	1100	970

## Performance curves

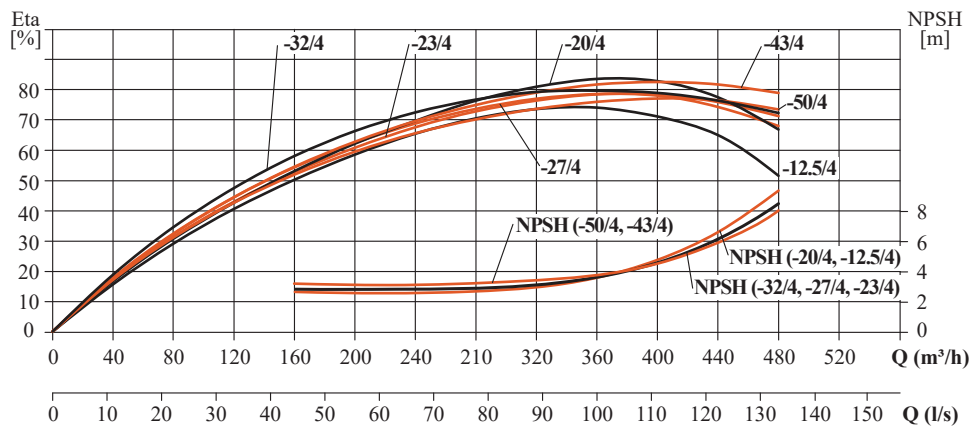
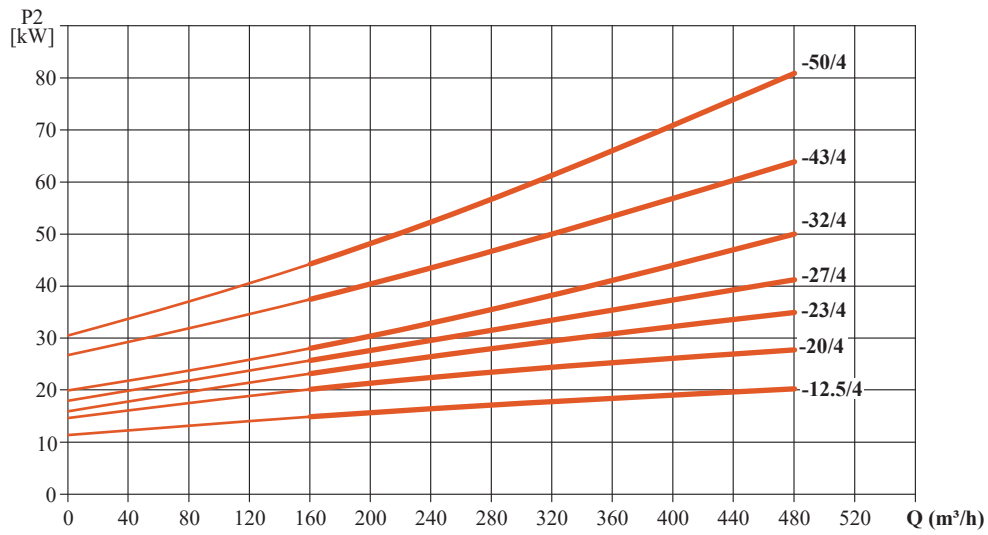
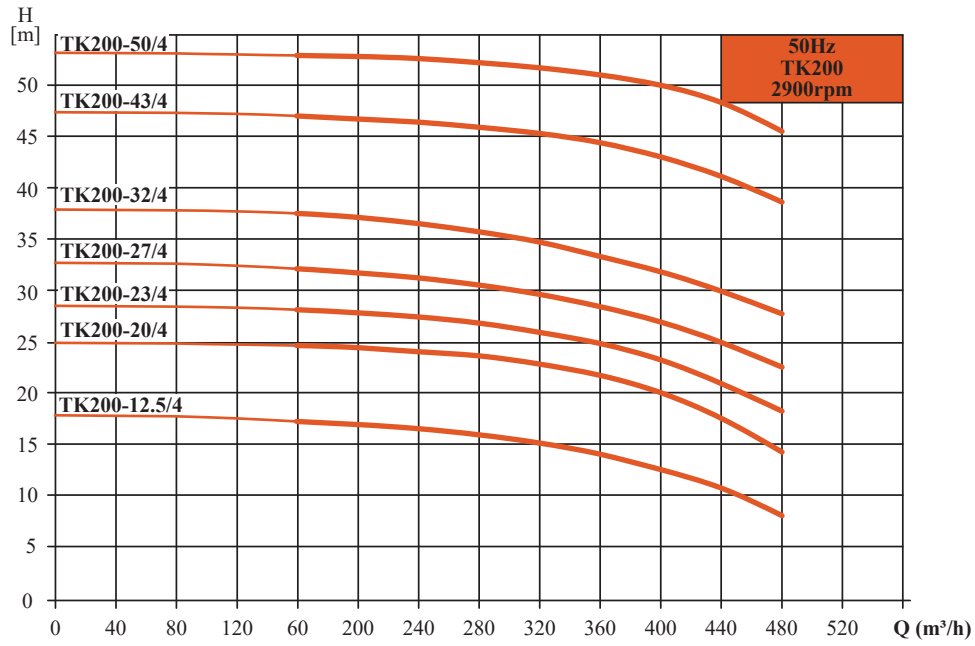

# TK250

1/2

## Performance data

Model	Power		Q (m <sup>3</sup> /h)	150	200	250	300	350	400	450	500	550	600
	kW	HP											
TK250-15/4	30	40	H (m)	18.7	18.4	18	17.6	17.1	16.4	15.8	15	14.1	12.6
TK250-18/4	37	50		21.1	20.9	20.5	20.1	19.7	19.2	18.7	18	17.1	15.8
TK250-21/4	45	60		24	23.8	23.5	23.1	22.8	22.3	21.8	21	20	18.7
TK250-27/4	55	75		30.2	30	29.6	29.2	28.8	28.3	27.7	27	26.1	24.8
TK250-36/4	75	100		39	38.8	38.5	38.2	37.8	37.3	36.8	36	35	33.3
TK250-44/4	90	120		47.3	47.1	46.8	46.4	45.9	45.4	44.8	44	43	41.5
TK250-53/4	110	150		56.1	55.9	55.6	55.3	54.8	54.3	53.7	53	52.1	50.8

## Installation dimensions & weight

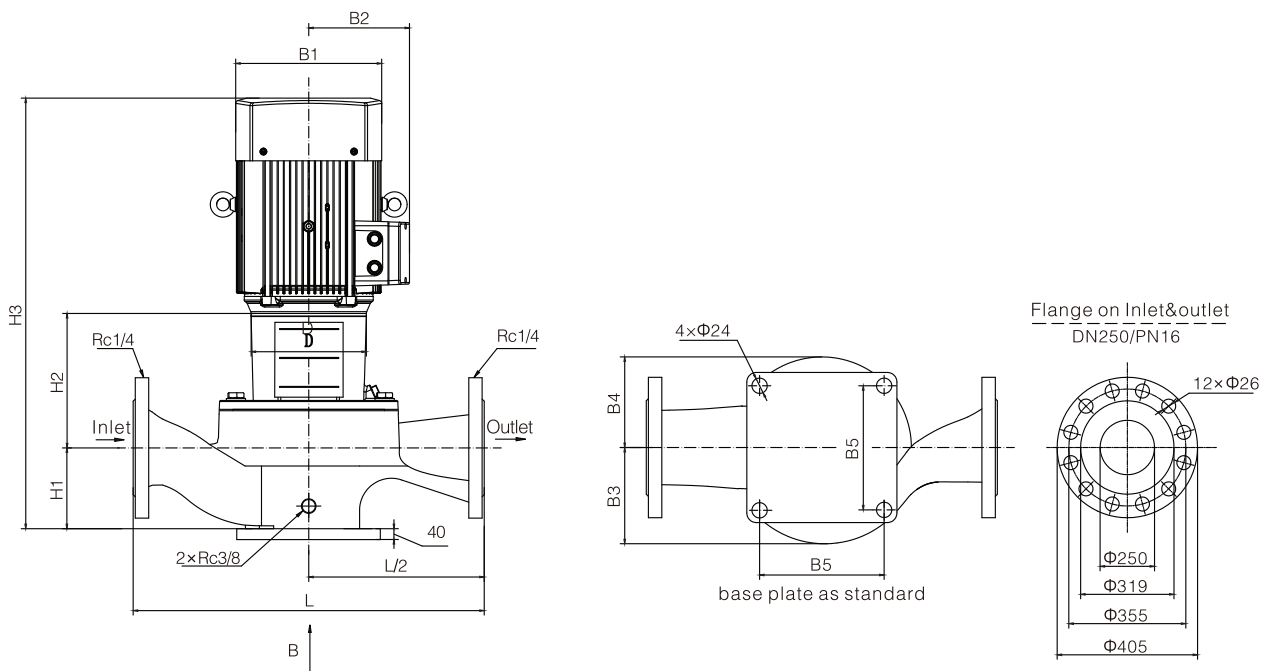

Model	Dimensions (mm)										Weight (kg)
	D	B1	B2	B3	B4	B5	H1	H2	H3	L	
TK250-15/4	400	400	305	315	242	390	300	393	1393	1100	564
TK250-18/4	450	450	335	315	242	390	300	423	1428	1100	636
TK250-21/4	450	450	335	315	242	390	300	423	1453	1100	660
TK250-27/4	550	490	365	328	263	440	300	438	1503	1100	802
TK250-36/4	550	550	370	328	263	440	300	438	1568	1100	949
TK250-44/4	550	550	410	346	291	440	305	461	1646	1200	1065
TK250-53/4	660	625	530	346	291	440	305	461	1826	1200	1292

## Performance curves

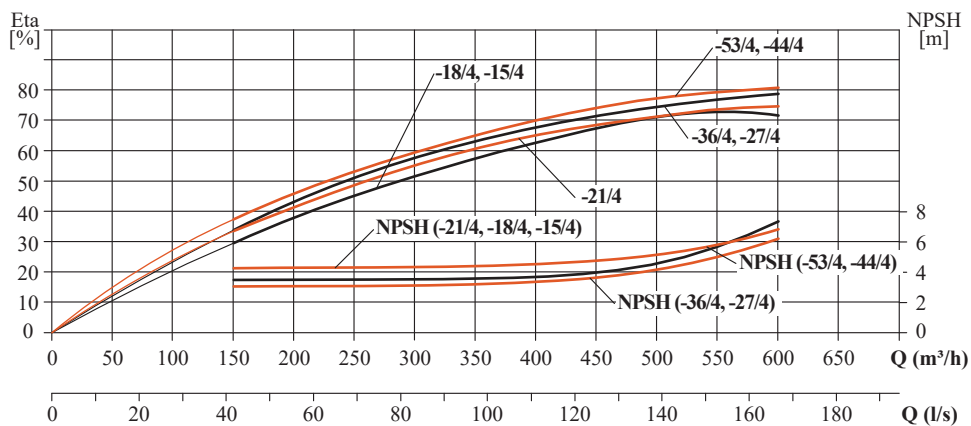
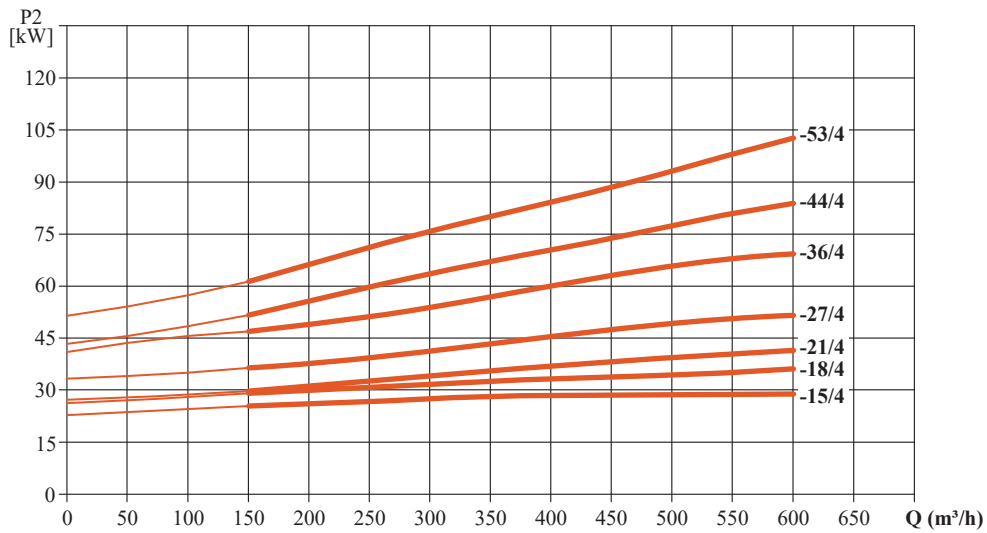
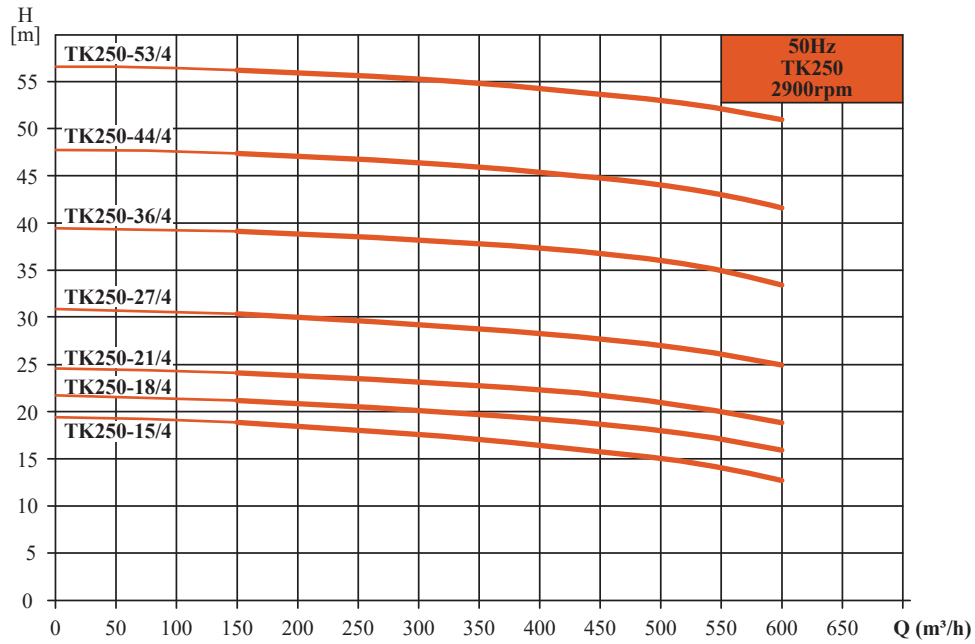

# TK250

2/2

## Performance data

Model	Power		Q (m <sup>3</sup> /h)	240	300	360	420	480	540	600	630	660	720	750
	kW	HP												
TK250-12.5/4	30	40	<b>H (m)</b>	18.3	17.9	17.2	16.4	15.5	14.5	13.2	12.5	11.8	9.9	8.6
TK250-14/4	37	50		19.9	19.5	18.9	18.2	17.5	16.6	15.6	14	13.4	12.6	11.5
TK250-17/4	45	60		21.7	21.3	20.8	20.1	19.4	18.6	17.6	17	16.3	14.4	13.3
TK250-20/4	55	75		24.4	24.1	23.7	23.1	22.4	21.5	20.5	20	19.3	17.6	16.4
TK250-26/4	75	100		31.6	31.1	30.6	29.9	29.1	28.2	26.8	26	25.2	23.1	21.8
TK250-32/4	90	120		36.6	36.3	35.7	35.1	34.3	33.5	32.6	32	31.3	29.5	28.3
TK250-40/4	110	150		45.9	45.5	44.9	44.2	43.4	42.3	40.8	40	39.1	36.8	35.4
TK250-50/4	132	175		55.5	55.2	54.6	53.9	53.2	52.3	50.9	50	49	46.7	45.3

## Installation dimensions & weight

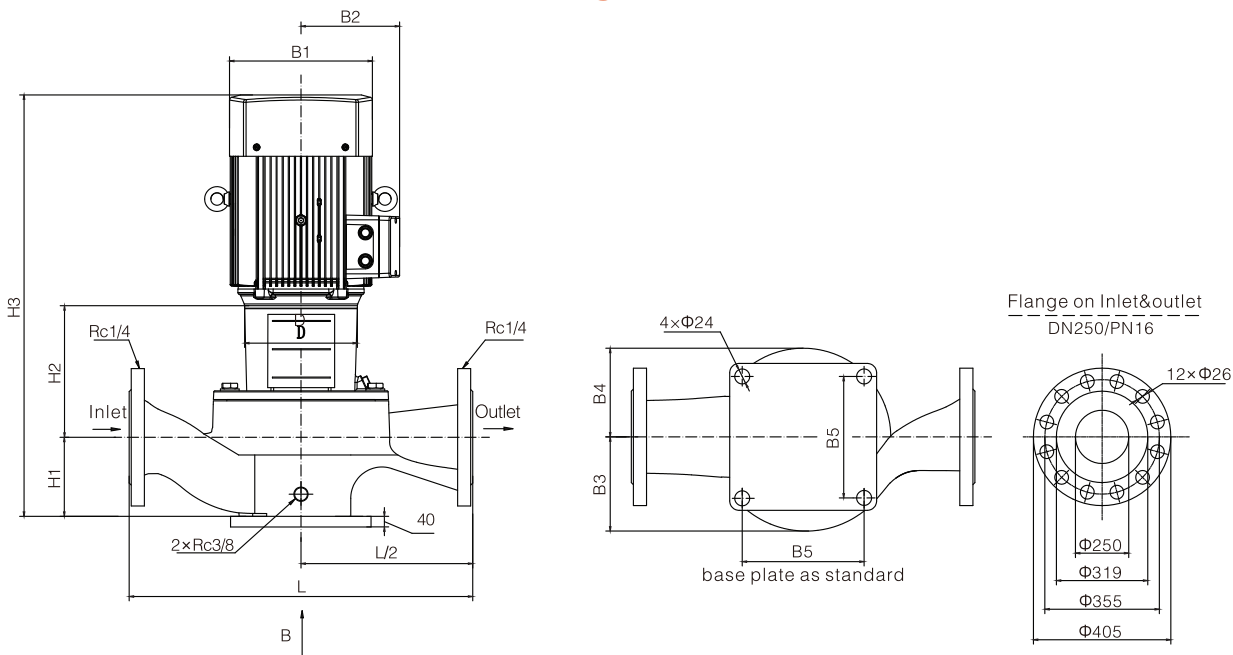

Model	Dimensions (mm)										Weight (kg)
	D	B1	B2	B3	B4	B5	H1	H2	H3	L	
TK250-12.5/4	400	400	305	315	242	390	300	393	1393	1100	563
TK250-14/4	450	450	335	315	242	390	300	423	1428	1100	635
TK250-17/4	450	450	335	315	242	390	300	423	1453	1100	659
TK250-20/4	550	490	370	315	242	390	300	423	1503	1100	759
TK250-26/4	550	550	410	328	263	440	300	438	1568	1100	948
TK250-32/4	550	550	410	328	263	440	300	438	1618	1100	1017
TK250-40/4	660	625	530	346	291	440	305	461	1826	1200	1290
TK250-50/4	660	625	530	346	291	440	305	461	1946	1200	1400



## Performance curves

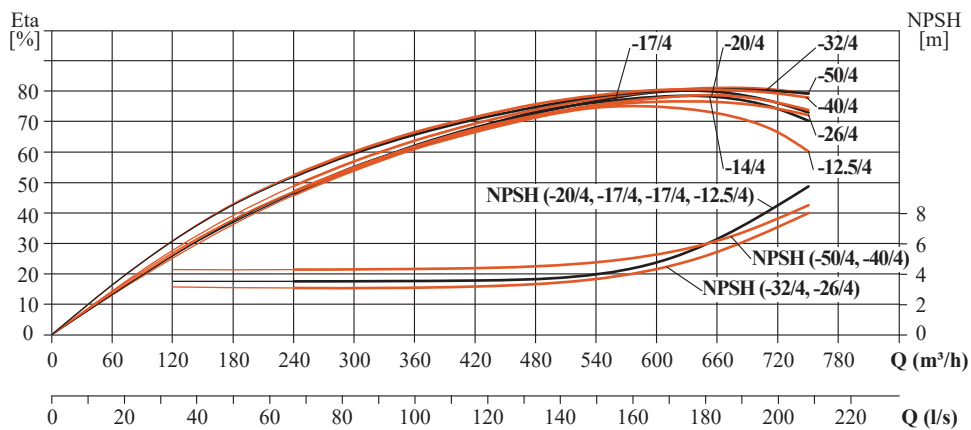
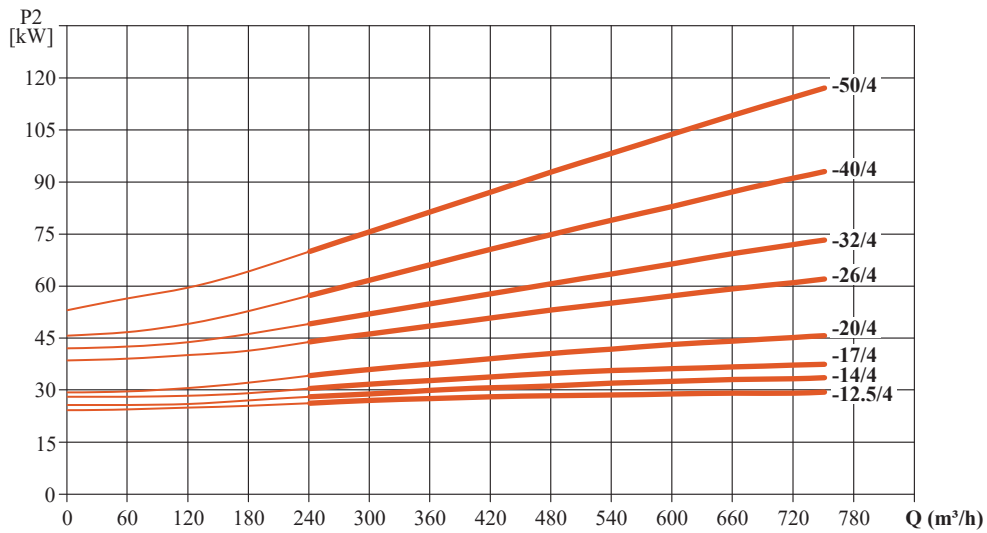
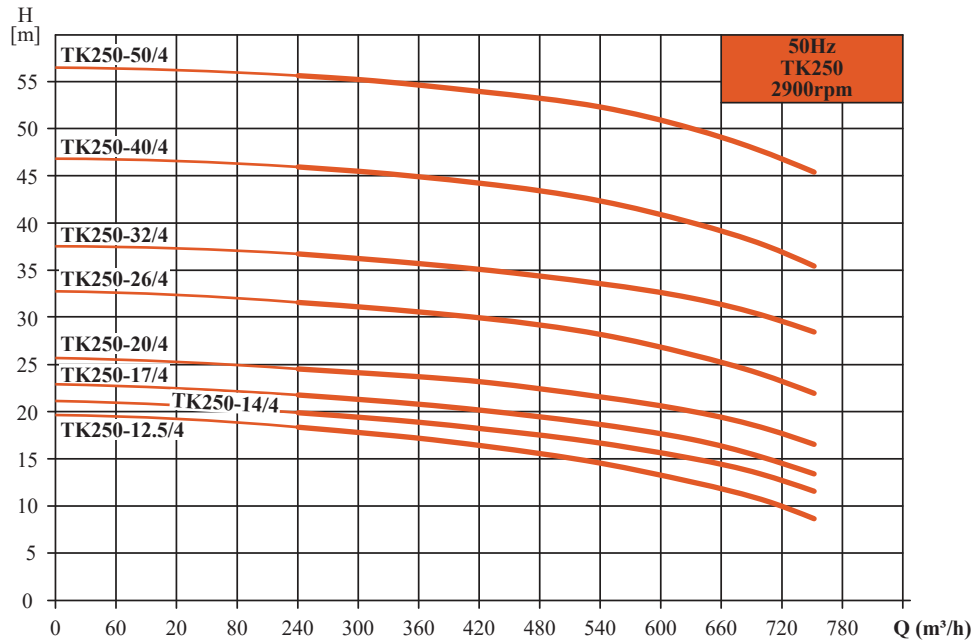

# TK3000

## Performance data

Model	Power		Q (m <sup>3</sup> /h)	270	360	450	630	750	900	1080	1200
	kW	HP									
TK300-15/4	55	75	H (m)	22.7	22.3	21.6	19.5	17.8	15	11.6	8.5
TK300-20/4	75	100		26.4	26	25.5	24.1	22.4	20	17.1	14.5
TK300-25/4	90	120		30.8	30.4	29.8	28.2	27.1	25	22.5	20
TK300-30/4	110	150		34.5	34	33.5	32.4	31.6	30	27.5	25
TK300-35/4	132	175		38.6	38.1	37.8	36.9	36	35	32.6	29.6
TK300-44/4	160	215		49.5	49.2	48.8	47.6	46.3	44	40.5	37.5
TK300-55/4	200	270		58.2	57.9	57.6	56.7	56.1	55	52.5	49.2

## Installation dimensions & weight

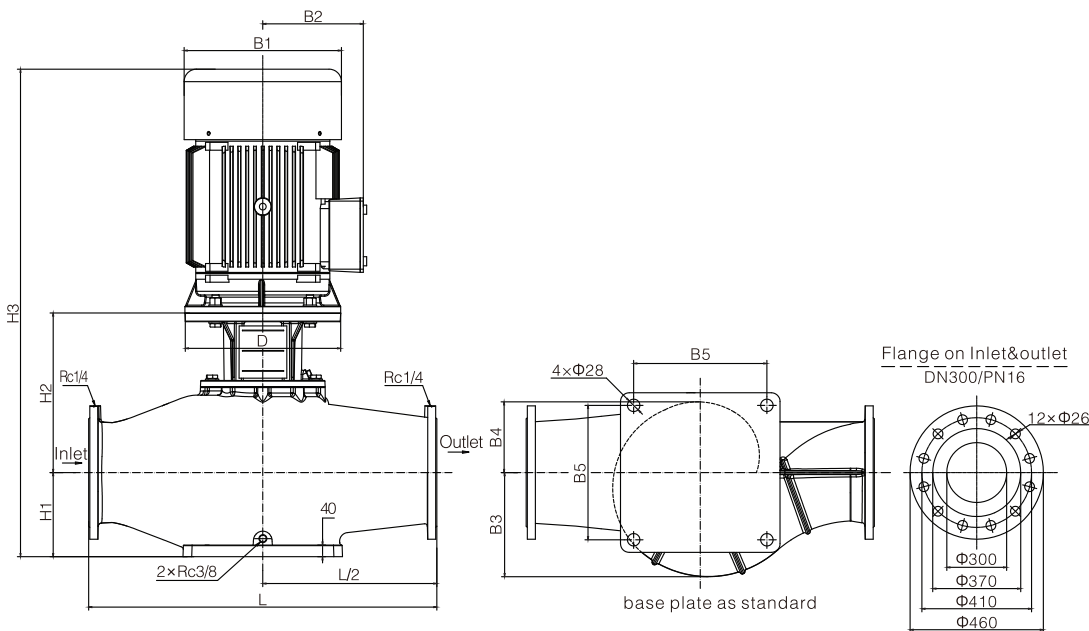

Model	Dimensions (mm)										Weight (kg)
	D	B1	B2	B3	B4	B5	H1	H2	H3	L	
TK300-15/4	550	490	365	344	249	440	290	649	1720	1200	907
TK300-20/4	550	550	400	344	249	440	290	649	1770	1200	1075
TK300-25/4	550	550	400	379	279	480	290	659	1850	1200	1230
TK300-30/4	660	625	550	379	279	480	290	699	2000	1200	1570
TK300-35/4	660	625	550	379	279	480	290	699	2150	1200	1650
TK300-44/4	660	625	550	379	294	480	290	702	2150	1200	1790
TK300-55/4	660	625	550	379	294	480	290	702	2150	1200	1905

## Performance curves

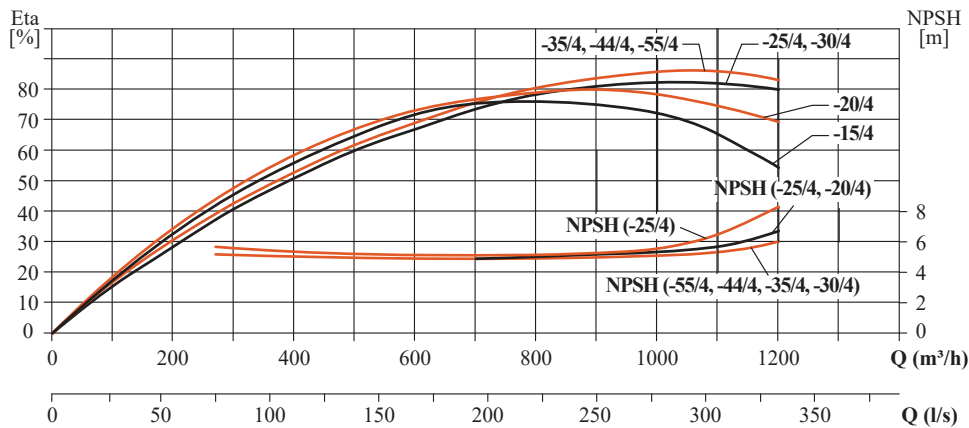
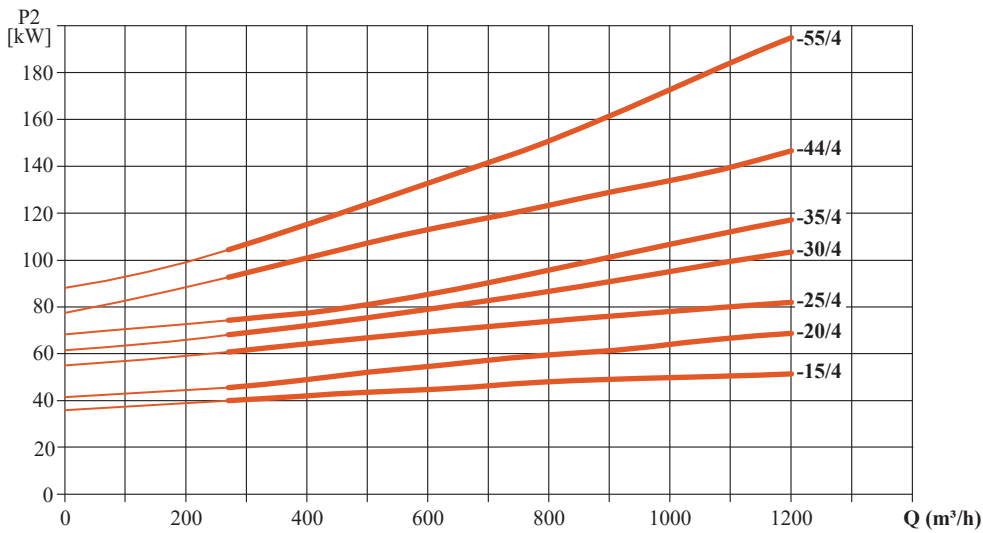
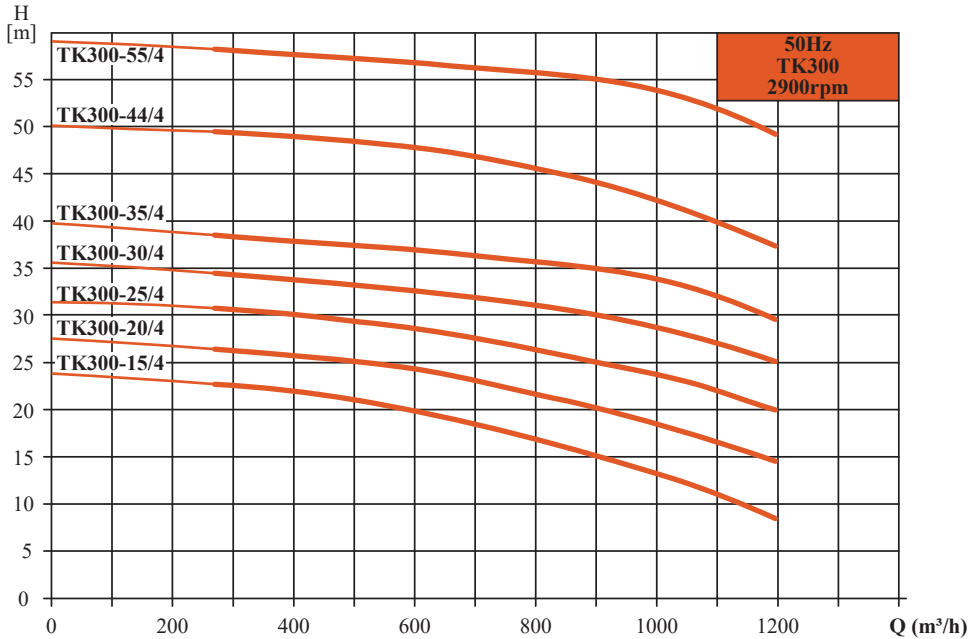

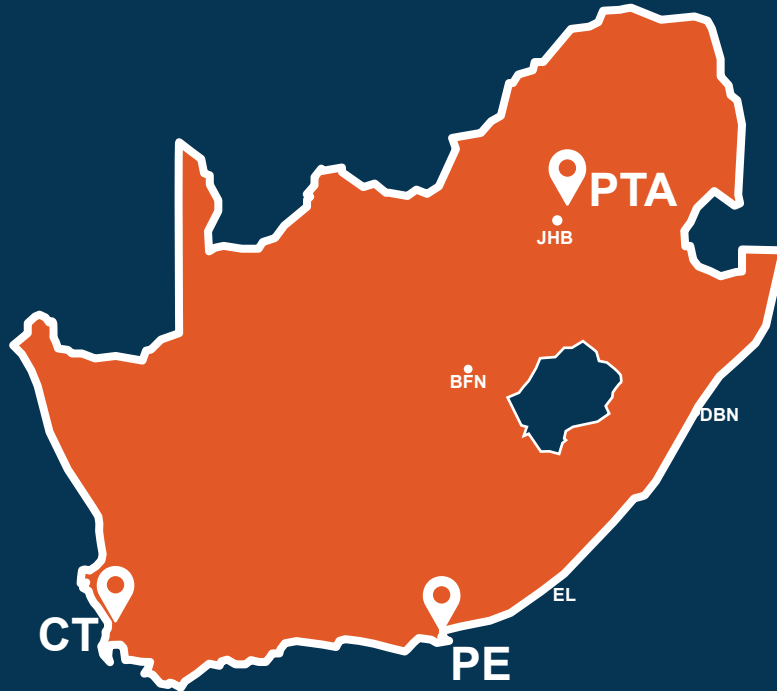

# vansan

WATER TECHNOLOGIES



**HEAD OFFICE:**  
+27 (012) 819-1196  
sales@vansan.co.za

**PE BRANCH:**  
+27 (041) 450 7803  
adminpe@vansan.co.za

**CAPE TOWN BRANCH:**  
+27 (021) 949 0902  
salescpt@vansan.co.za

[www.vansan.co.za](http://www.vansan.co.za)

