

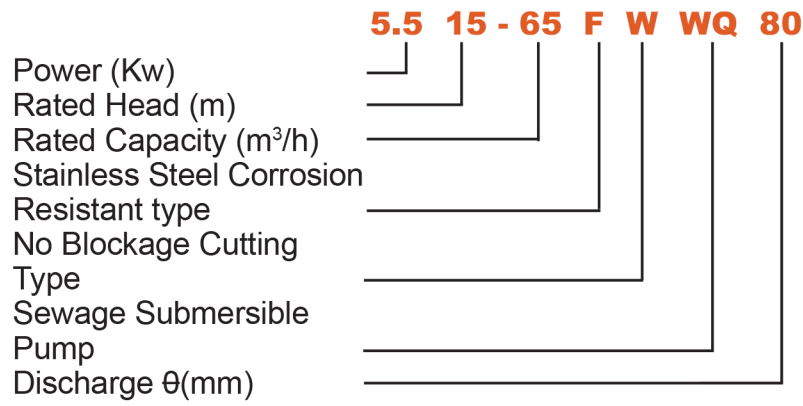

Sewage Submersible Pump

Main Application: Discharge waste water, rainwater and sewage
Motor: IPX8 protection level and F-level insulation
Shaft Seal: Oil filled
Cable: Sewage-resistant flexible cable with rubber sheath



WQF cast iron automatic coupling mounting dimension

Pump Outlet Diameter	50	65	80	100	150	200	250	300
Item								
Guide pipe dimensions	1" x (θ 30 x 2)			1.5" x (θ 45 x 2)			2" x (θ 55 x 2.5)	
Guide pipe length (mm)	-80							
Specification and quantity of expansion bolts	M12 x 80 x 2				M14 x 100 x 2		M16 x 120 x 2	
Specification and quantity of anchor bolts	M16 x 250 x 4						M20 x 300 x 4	
Size of hole reserved for anchor bolt	80 x 80 x 300						100 x 100 x 350	
Inner diameter of rubber hose (mm)	50	65	80	100	150	200	250	300